

EMERALD

Gnosis Soft Factory Design 1997.11.21
A. Scott Howe, architect

An example floor plan

The following is an example floor plan to show the correct placement of the EMERALD Gnosis soft factory design kit-of-parts components. The drawings start with space zone / structure zone layouts and also include framing plan, floor plan, and roof plan.

Zoning Plan

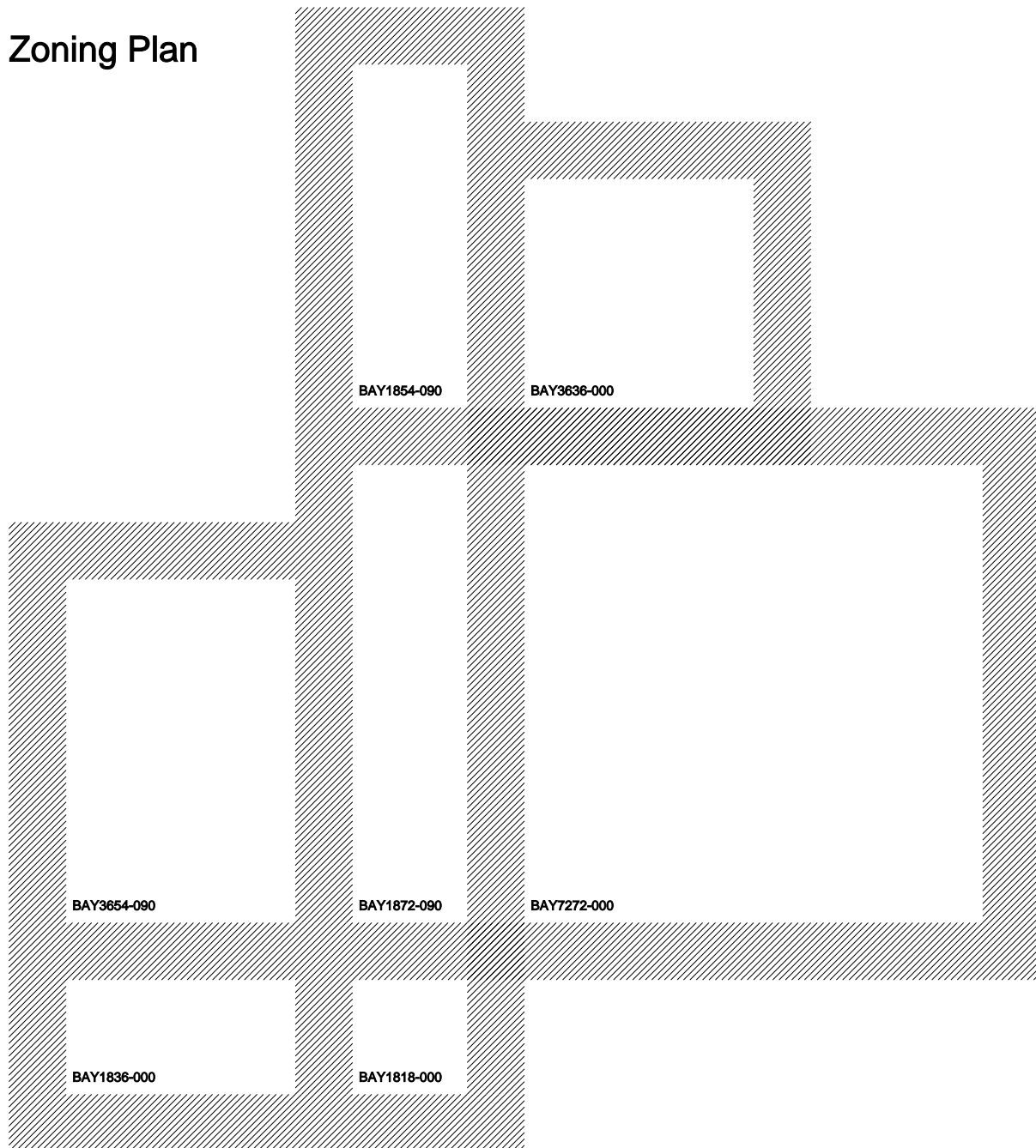

Framing Plan

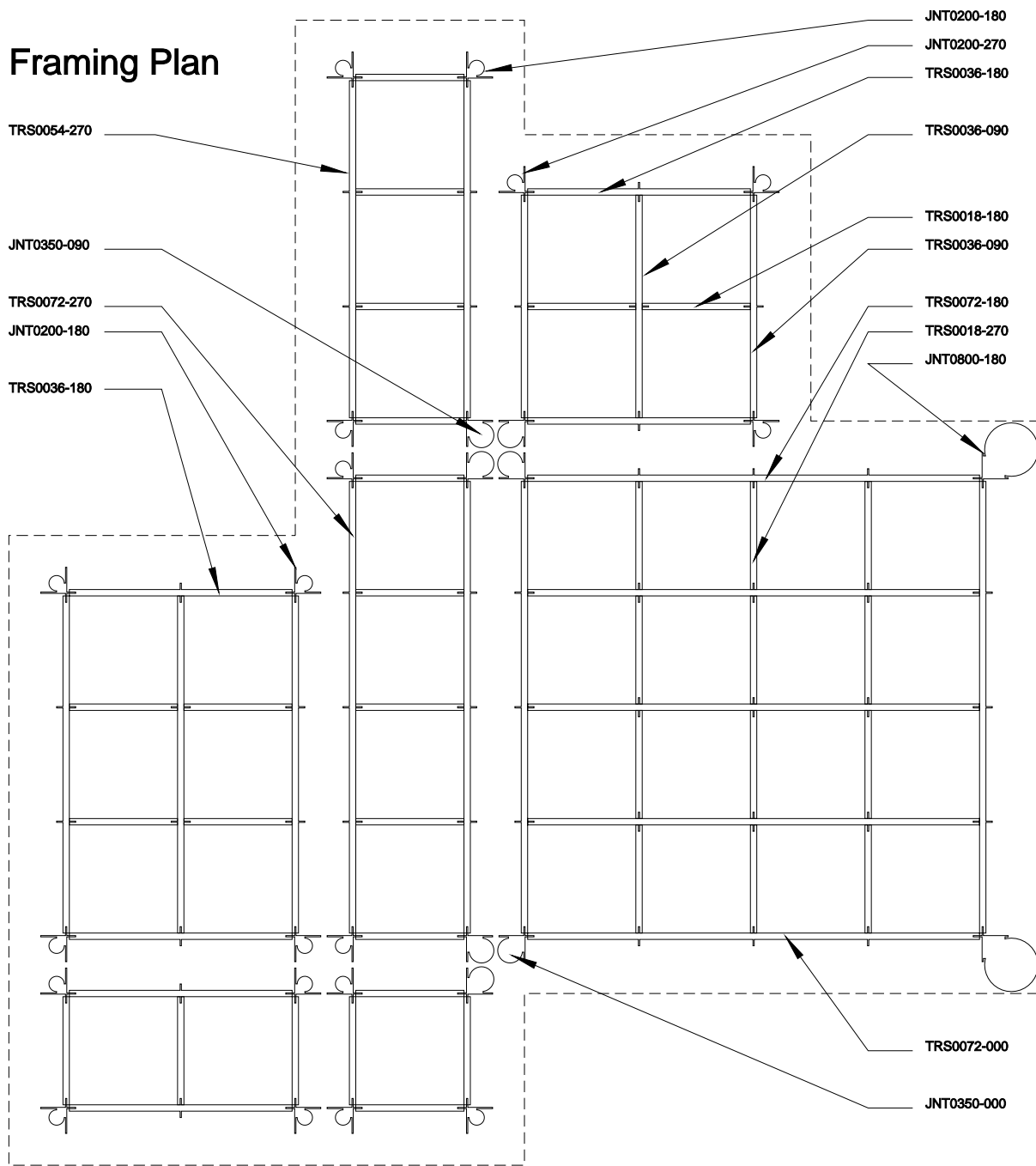

Floor Plan

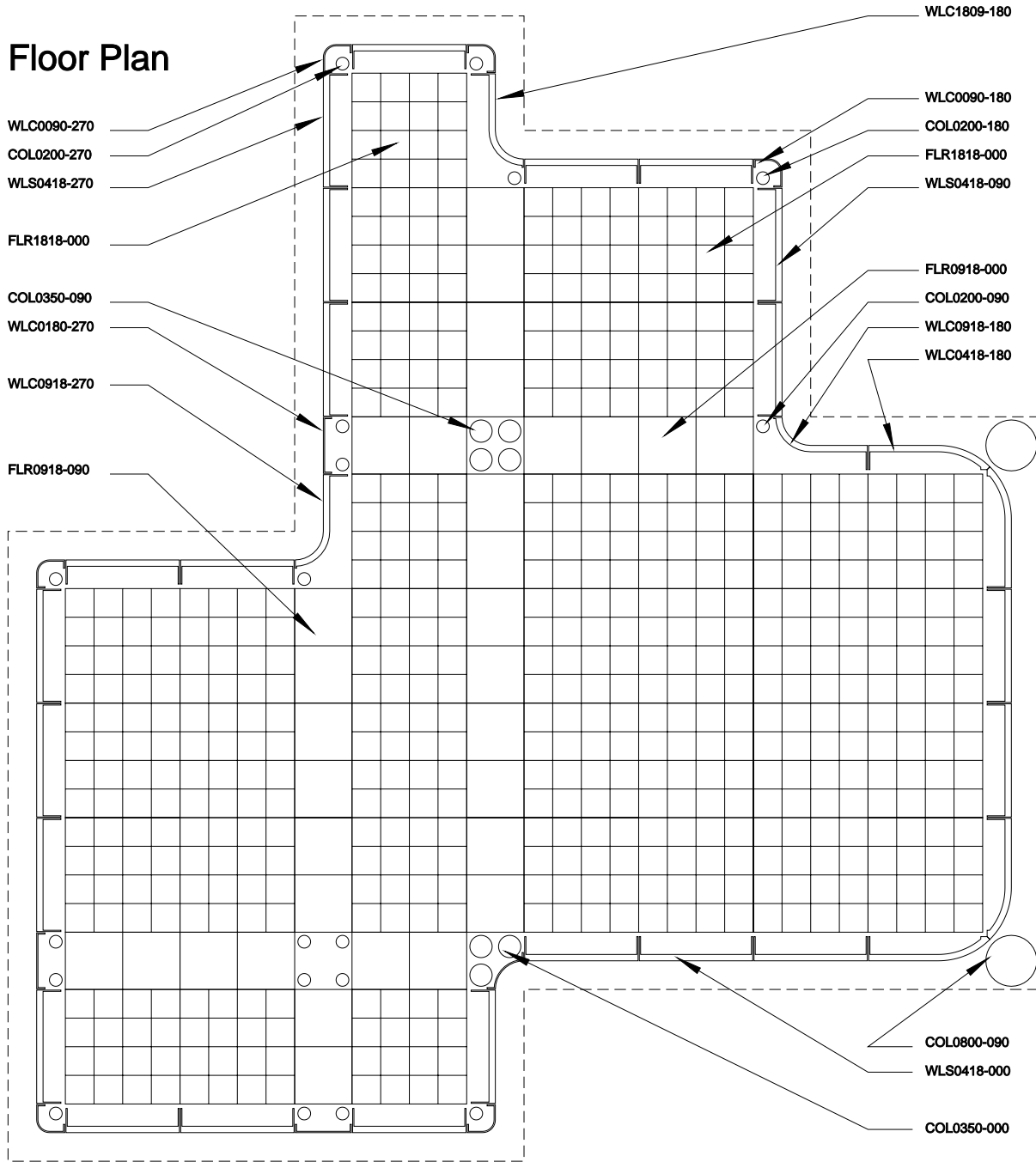

Roof Plan

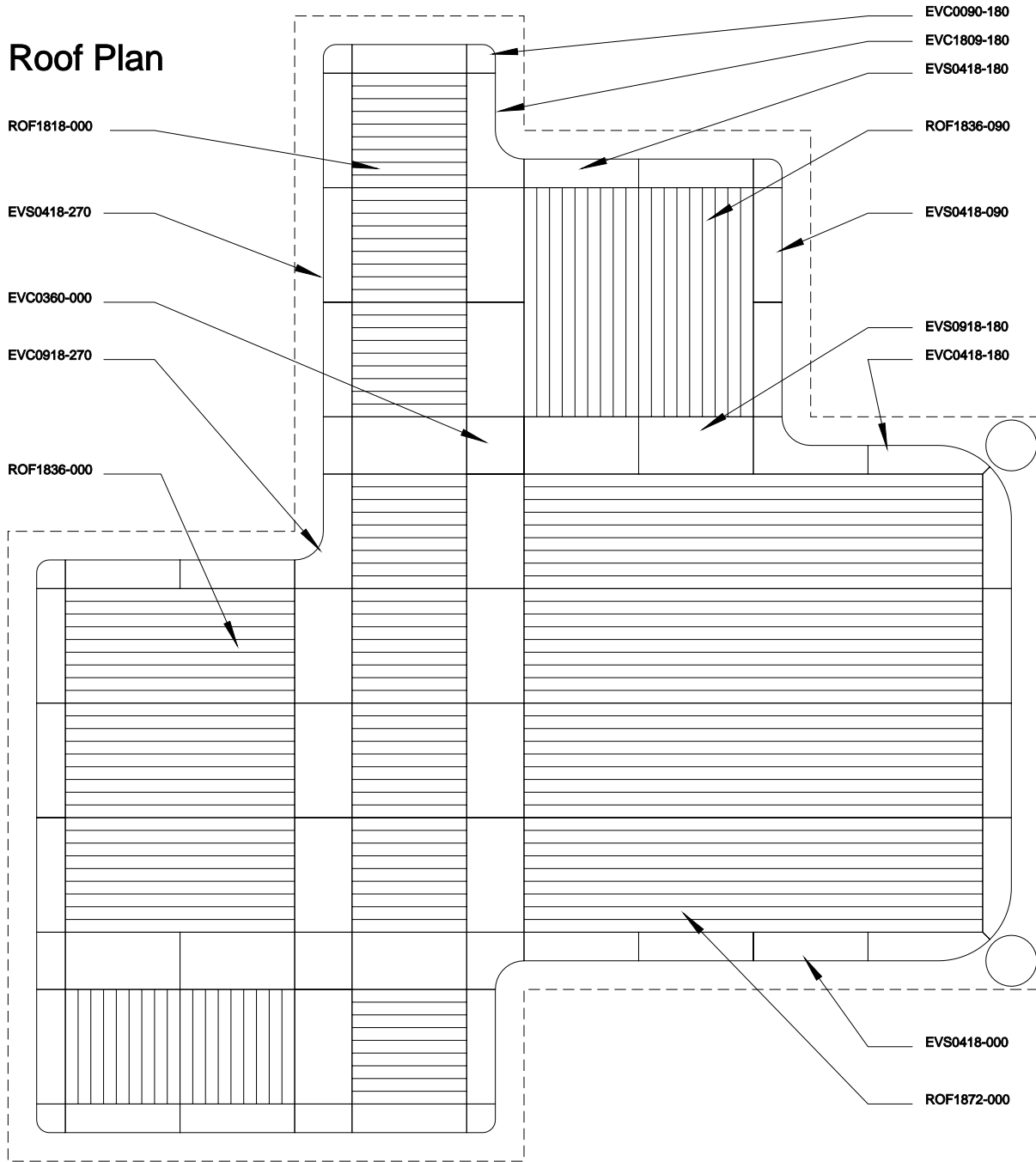

Possible bay sizes

Possible bay sizes for the EMERALD Gnosis soft factory design are shown on the following pages. Each bay size has a unique name, which is derived from the bay size itself. The bay diagrams are laid out on a graphical grid such as that shown below.

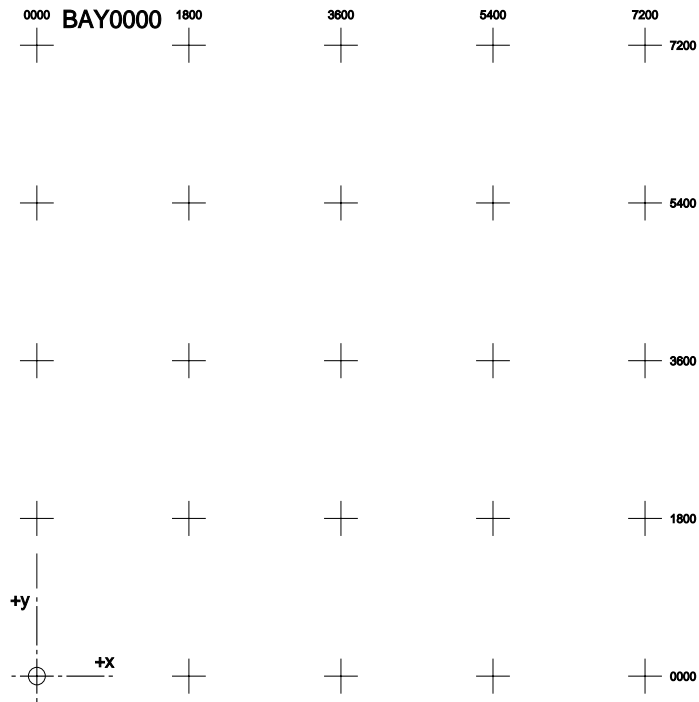

0000 BAY1818 1800 3600 5400 7200 7200

5400

3600

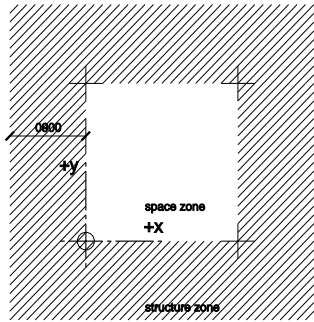

1800

0000

0000 BAY1836 1800 3600 5400 7200 7200

5400

3600

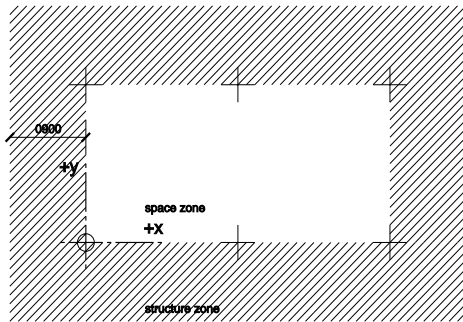

1800

0000

0000 BAY1854 1800 3600 5400 7200 7200

5400

3600

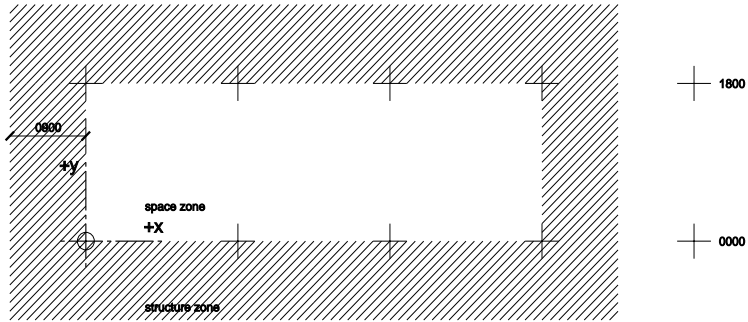

0000 BAY1872 1800 3600 5400 7200 7200

5400

3600

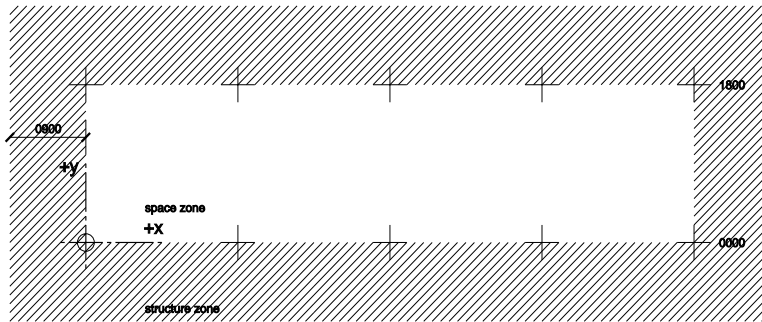

0000 BAY3636 1800 3600 5400 7200 7200

5400

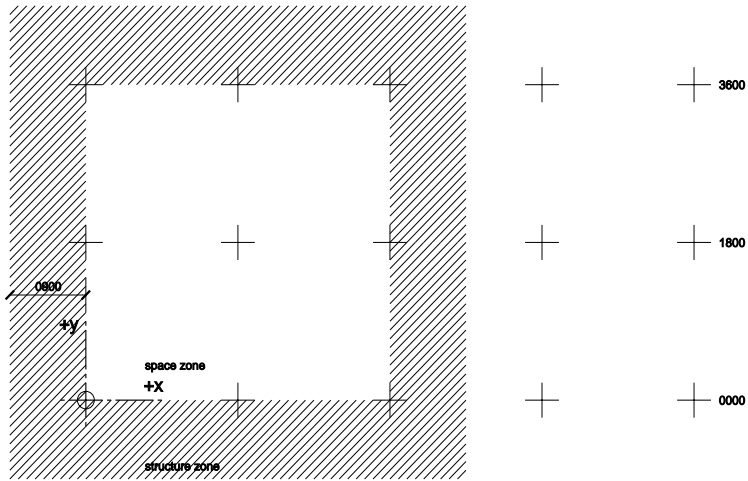

0000 BAY3654 1800 3600 5400 7200 7200

5400

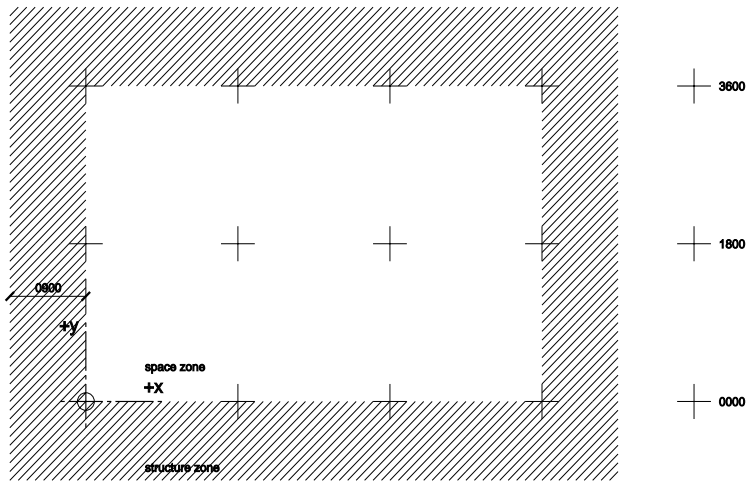

0000 BAY5472 1800 3600 5400 7200 7200

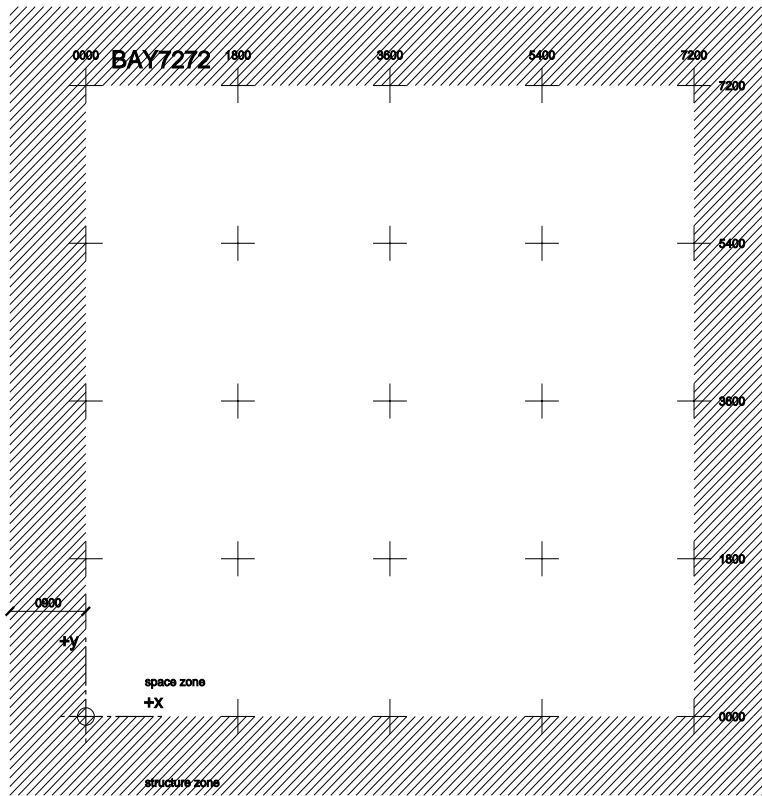
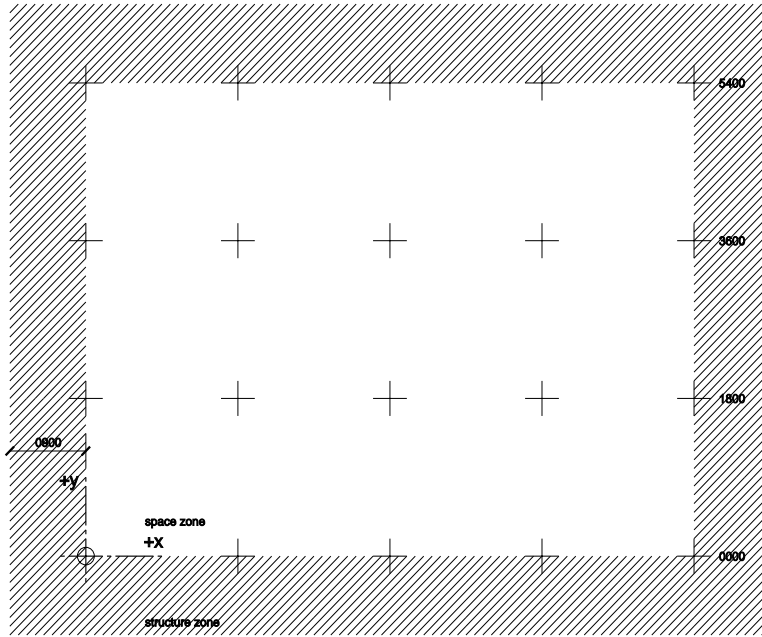

Possible component types

Each of the possible component types for the EMERALD Gnosis soft factory design has a unique name, which is derived from the component size and type. The component diagrams are laid out on a graphical scaling grid such as that shown below.

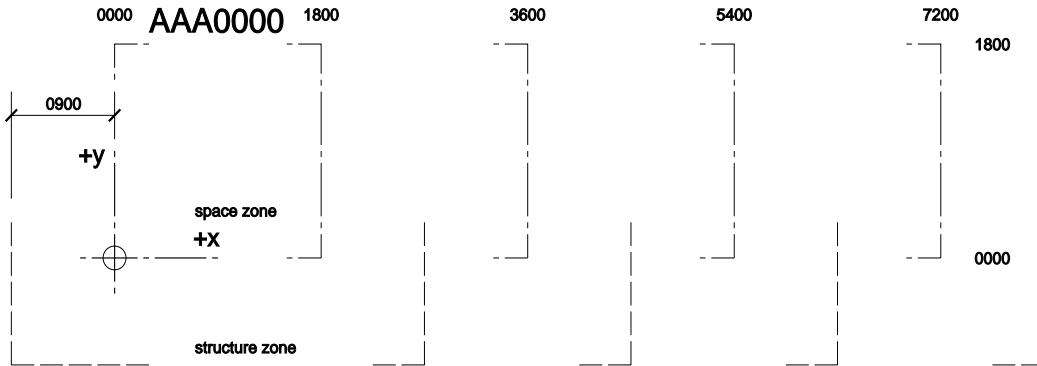

In addition to regular components, a special parameterized structure zone component is shown below. This component is not included in the library, but is needed as a ghost component in the VRML model complexity level 1.

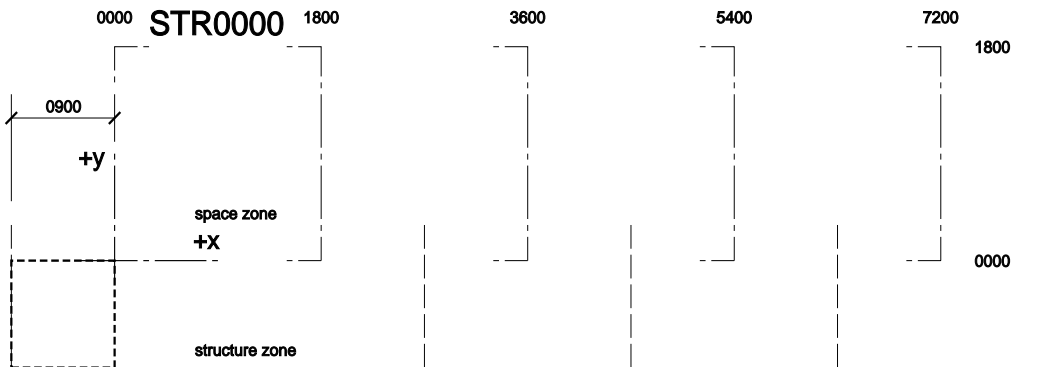

The regular components are shown on the following pages. The components included represent only enough types to construct the plan at the beginning of this report. The components are generic, and would be modular to the extent that other sub types could be derived from the basic type. Sub types could include doors, windows, shading devices, etc.

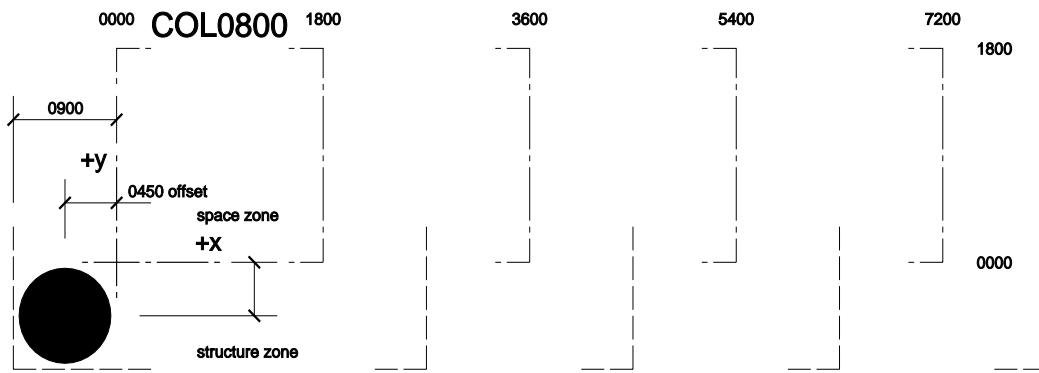
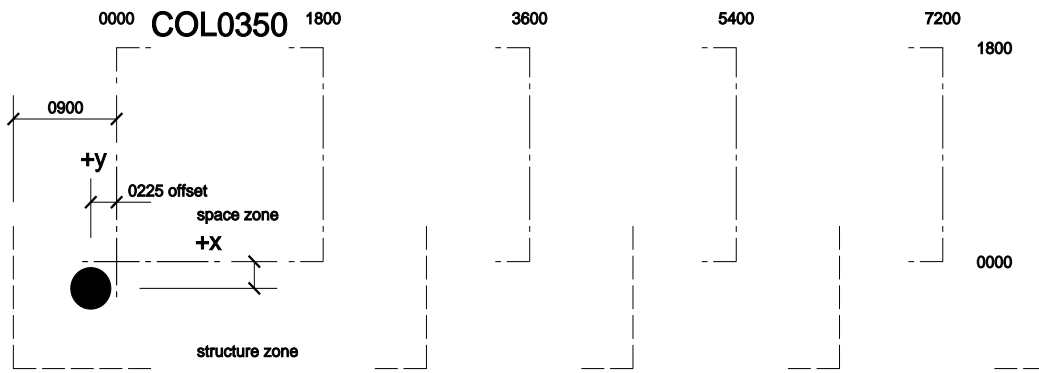
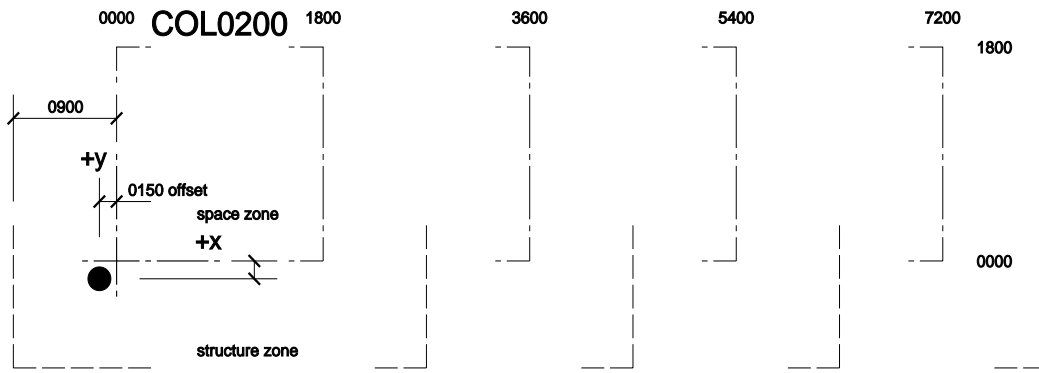

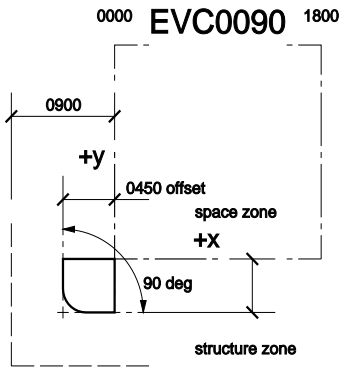

3600

5400

7200

1800

0000

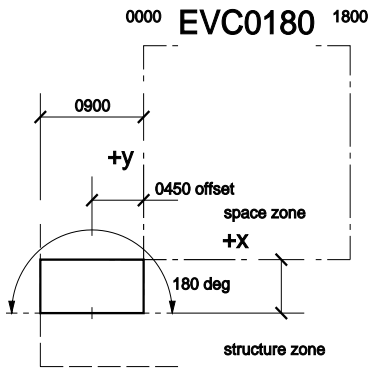

3600

5400

7200

1800

0000

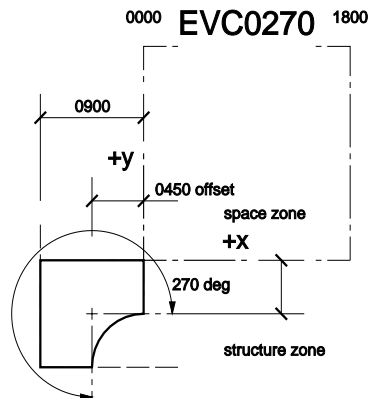

3600

5400

7200

1800

0000

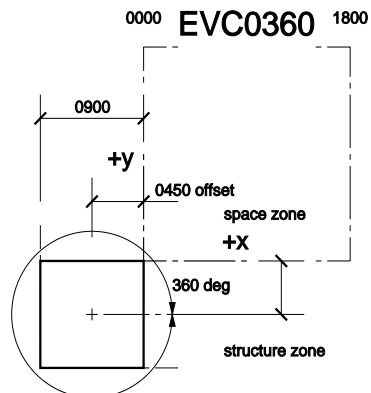

3600

5400

7200

1800

0000

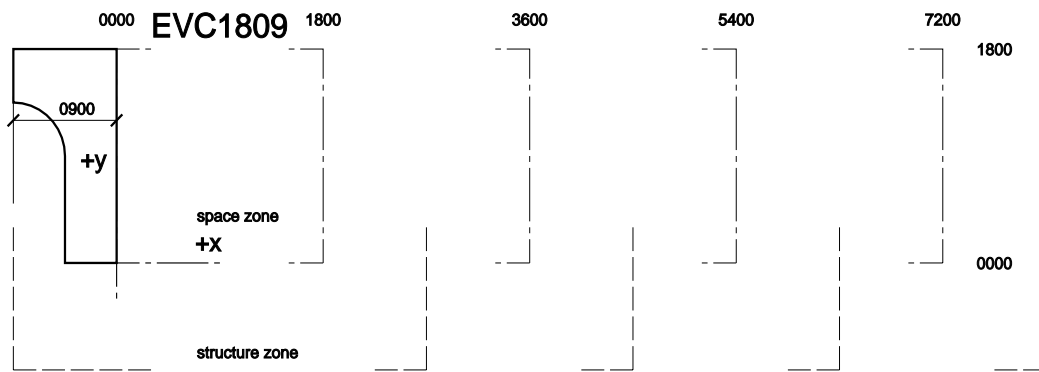
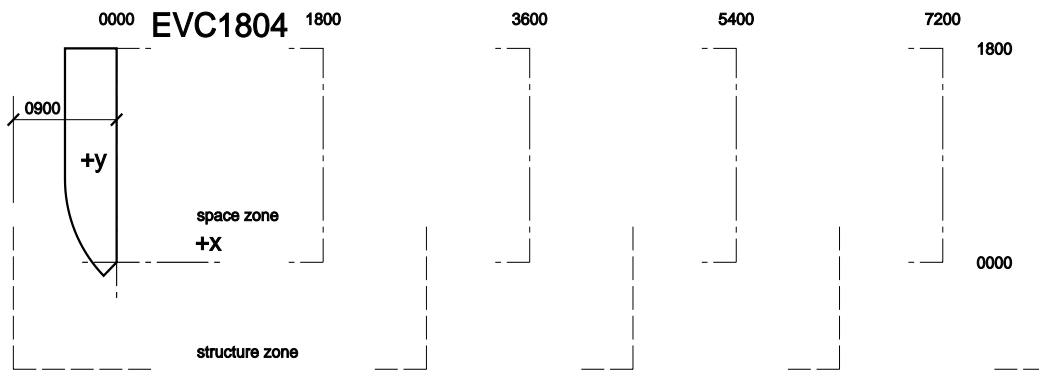
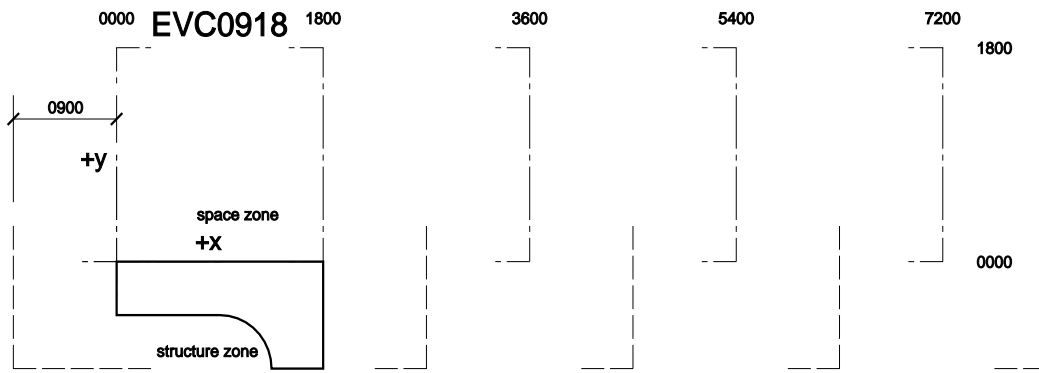
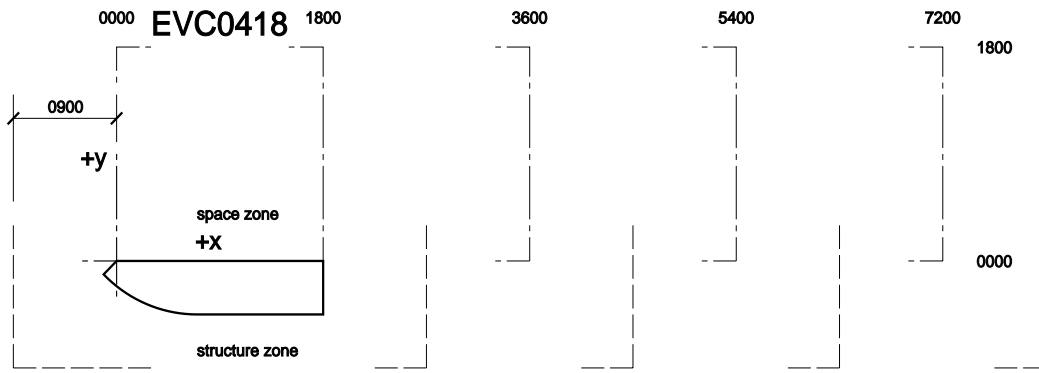

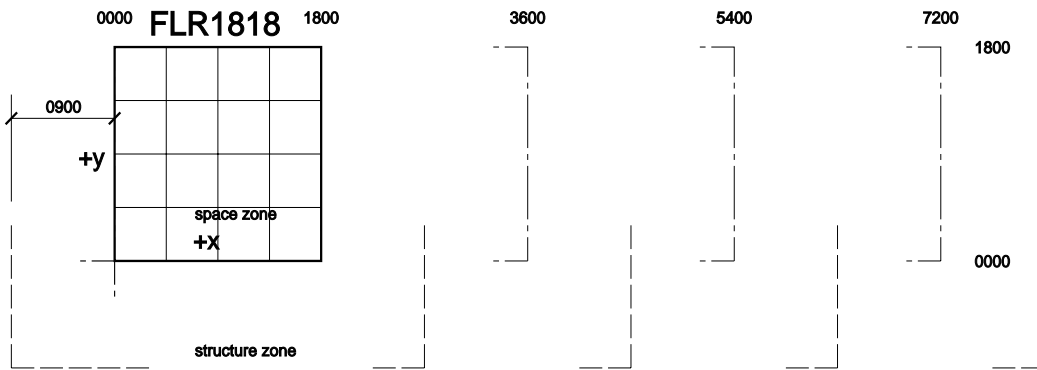
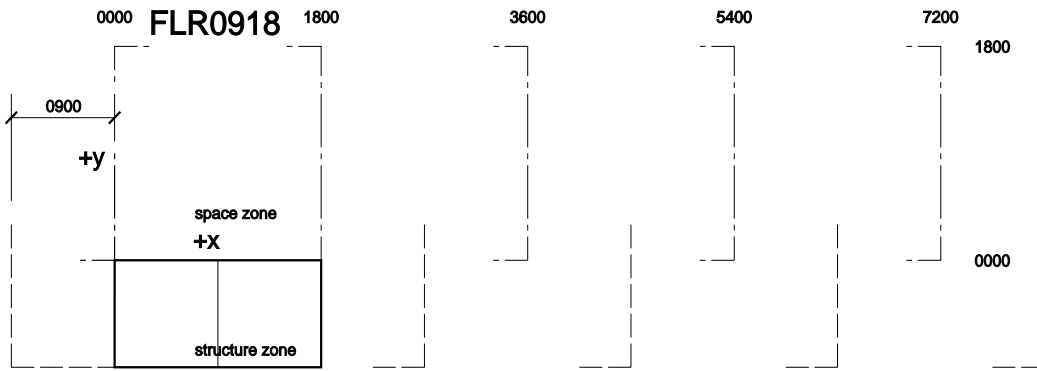
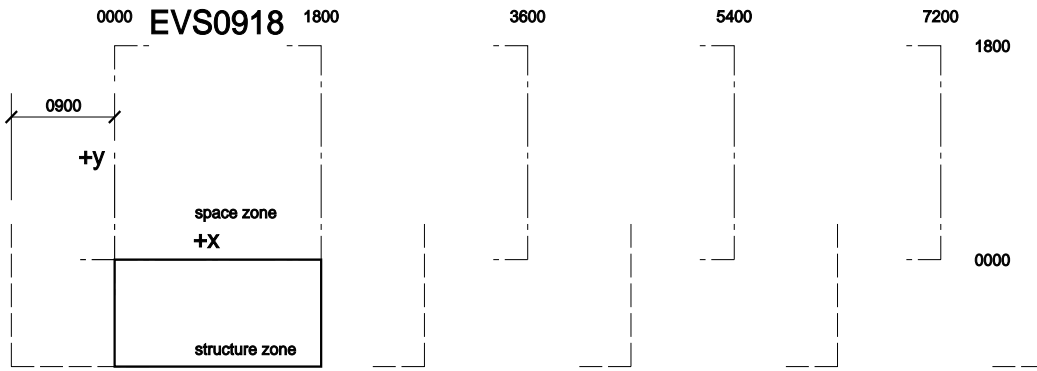
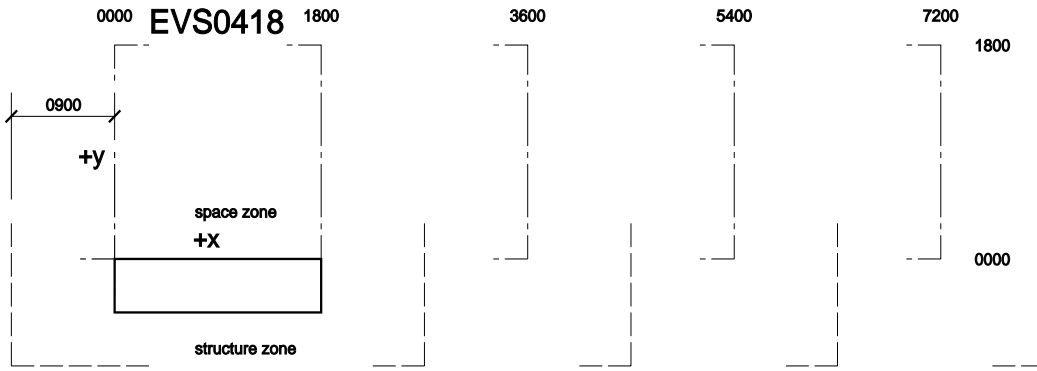

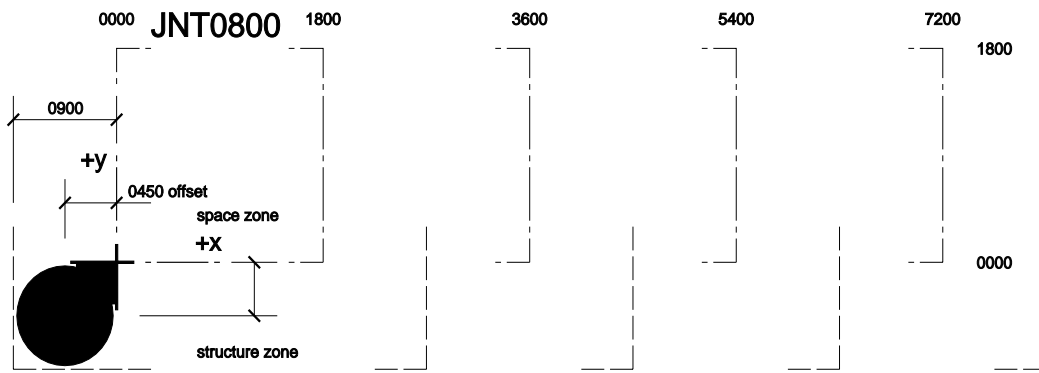
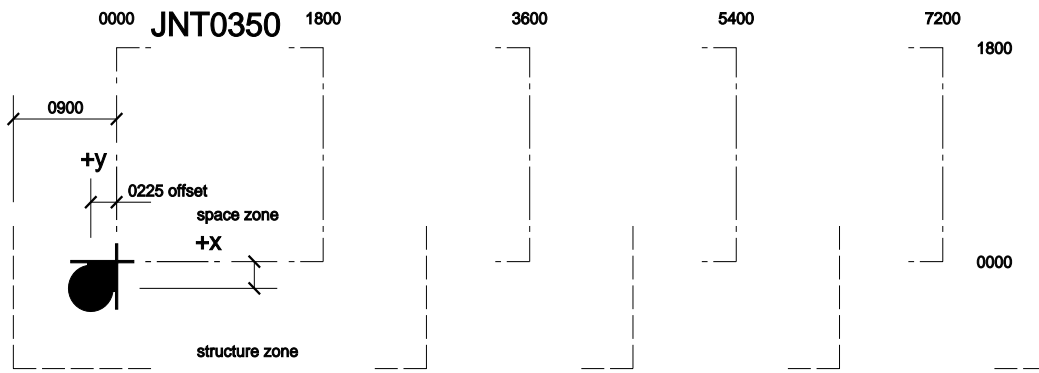
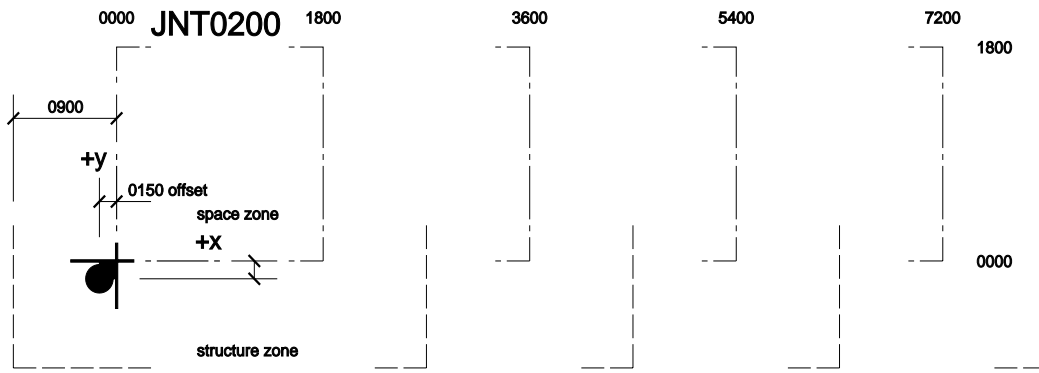

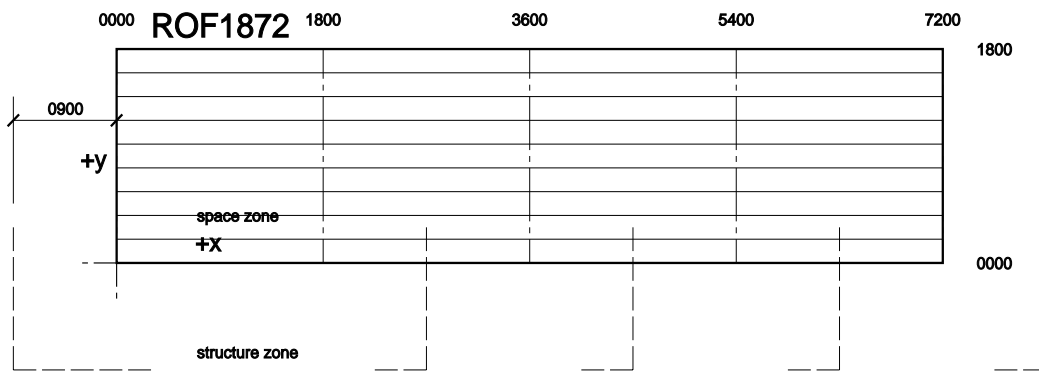
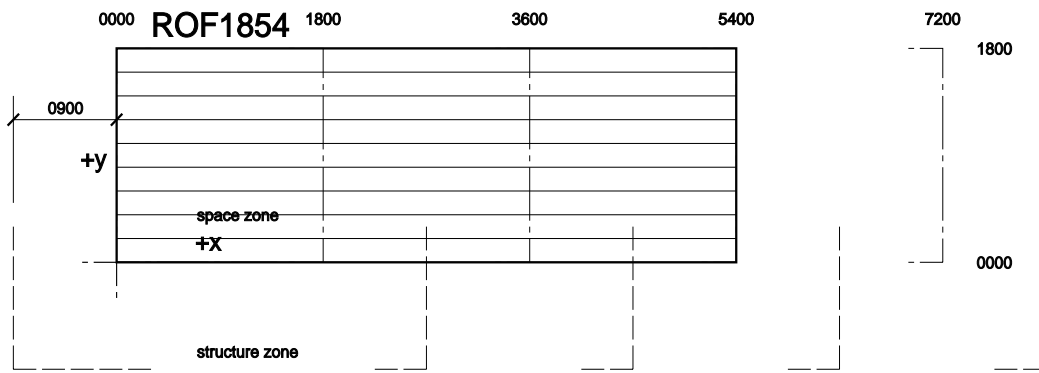
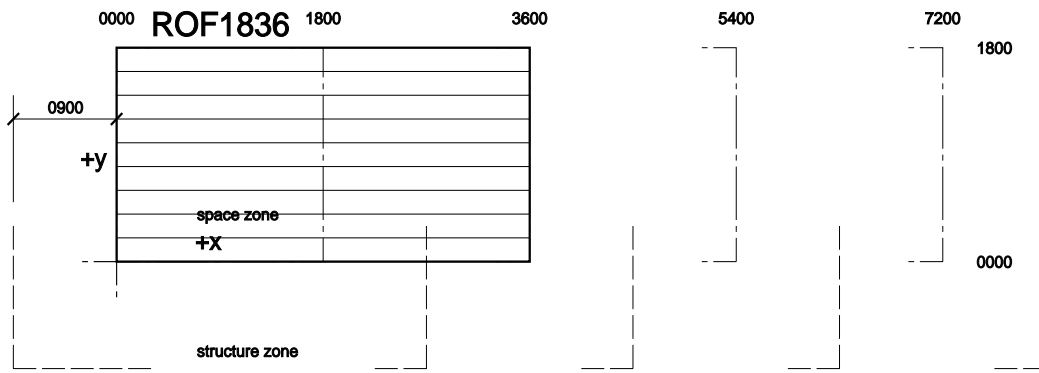
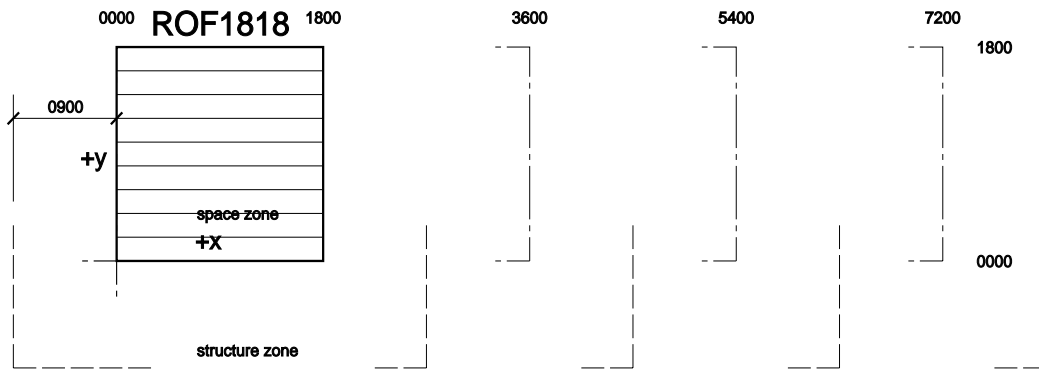

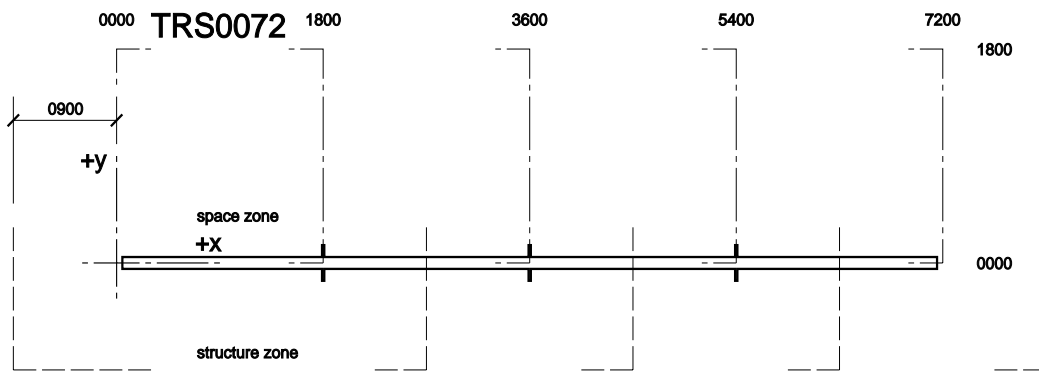
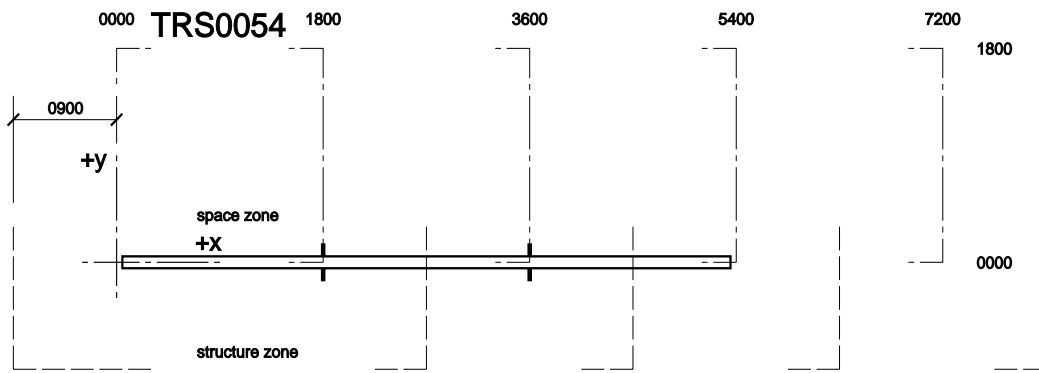
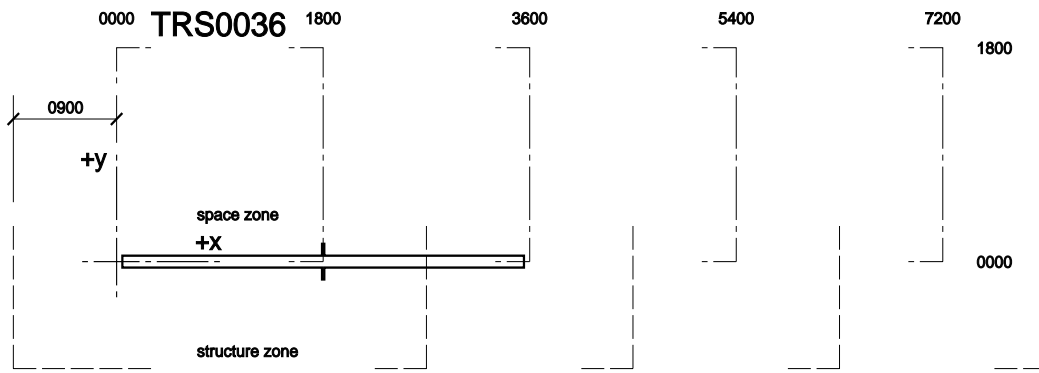
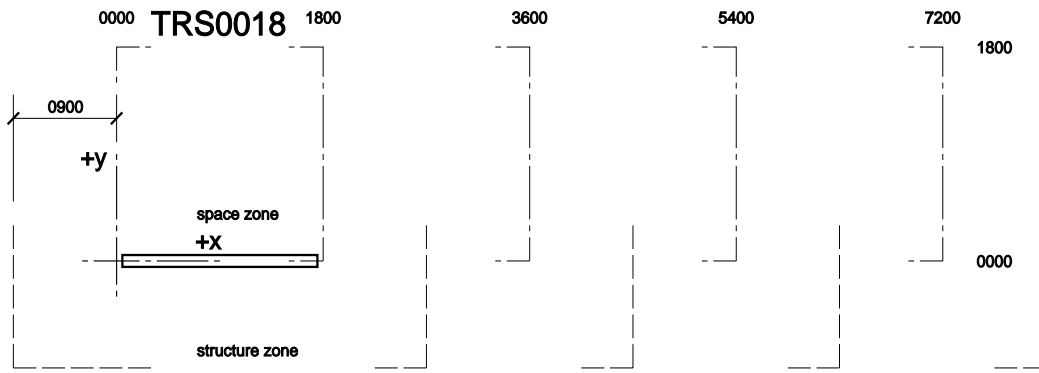

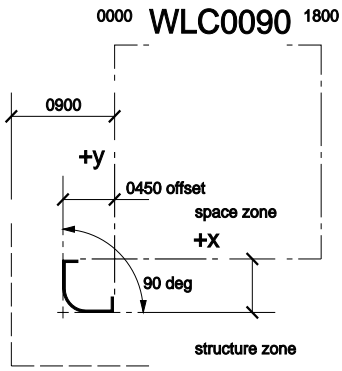

3600

5400

7200

1800

0000

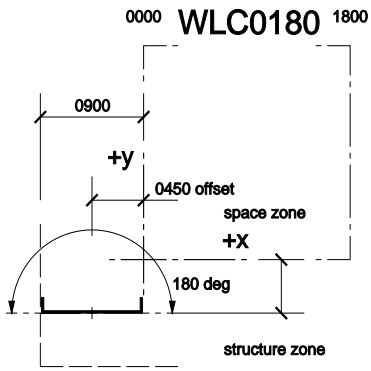

3600

5400

7200

1800

0000

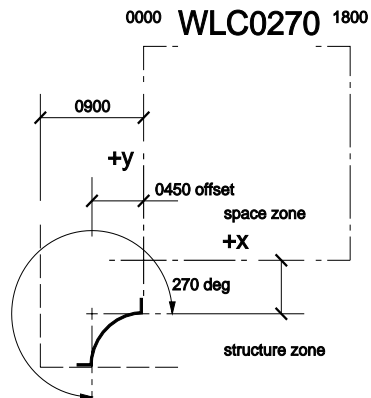

3600

5400

7200

1800

0000

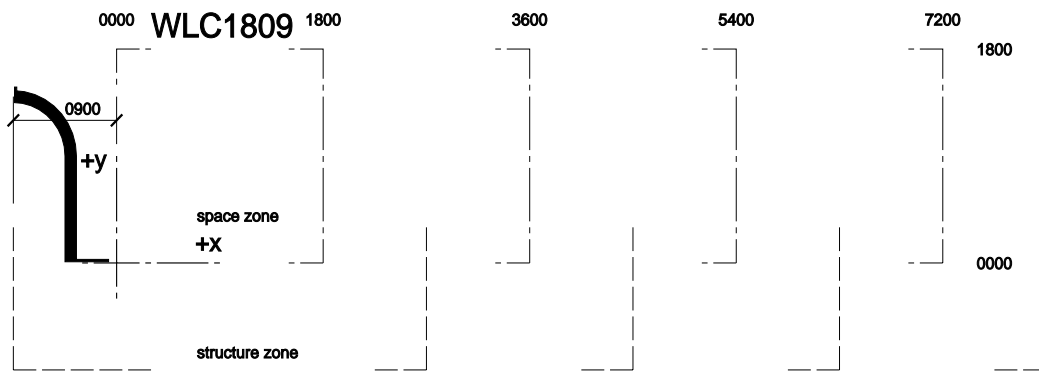
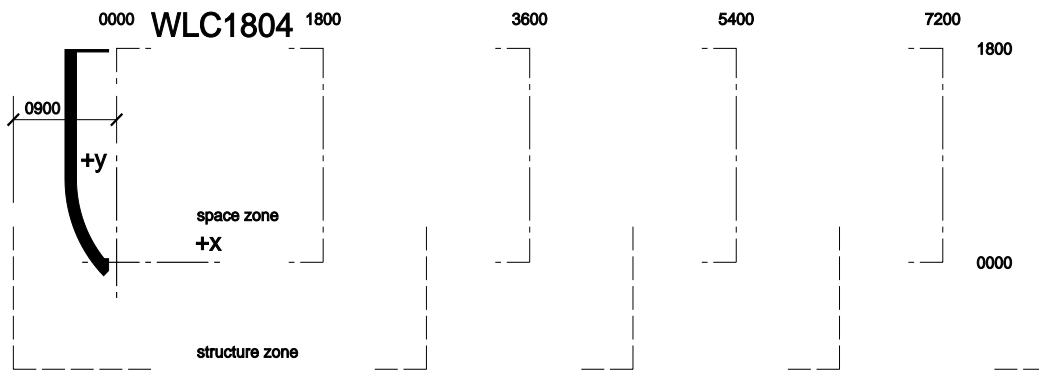
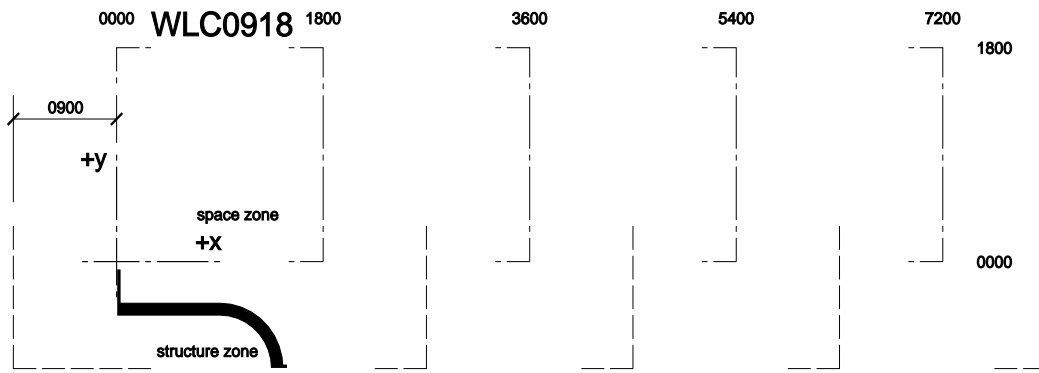
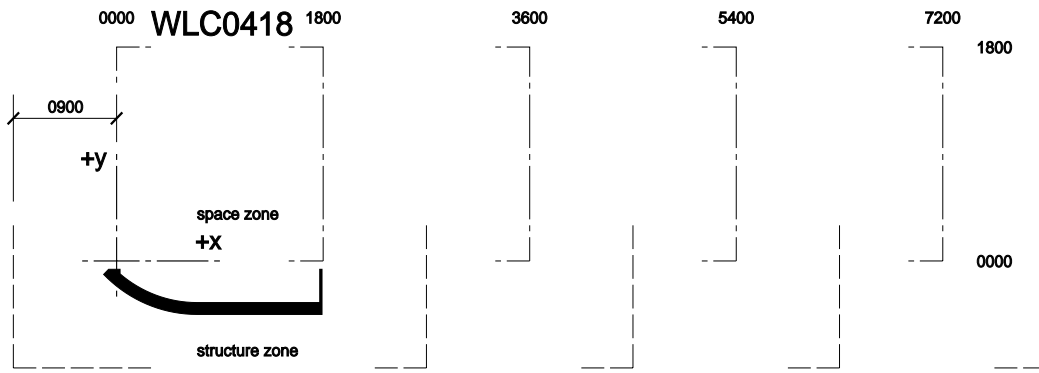

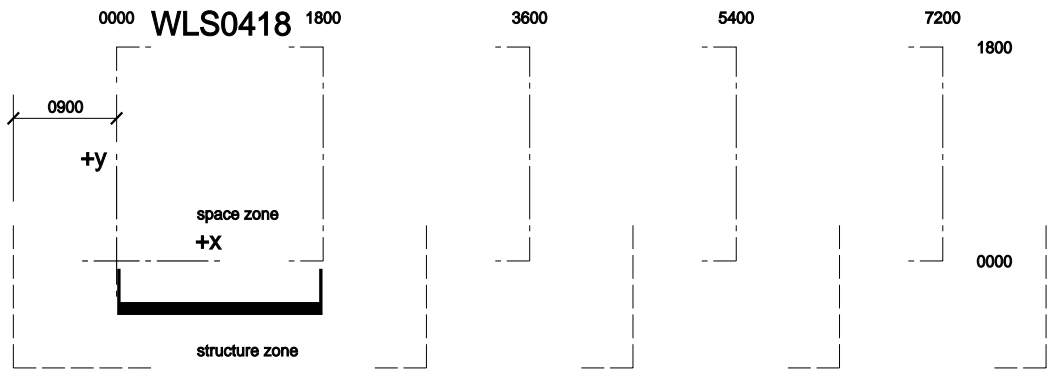

Three-dimensional components

On the following pages are three-dimensional versions of the EMERALD Gnosis soft factory kit-of-parts components. The component diagrams are laid out on a graphical scaling grid such as that shown below.

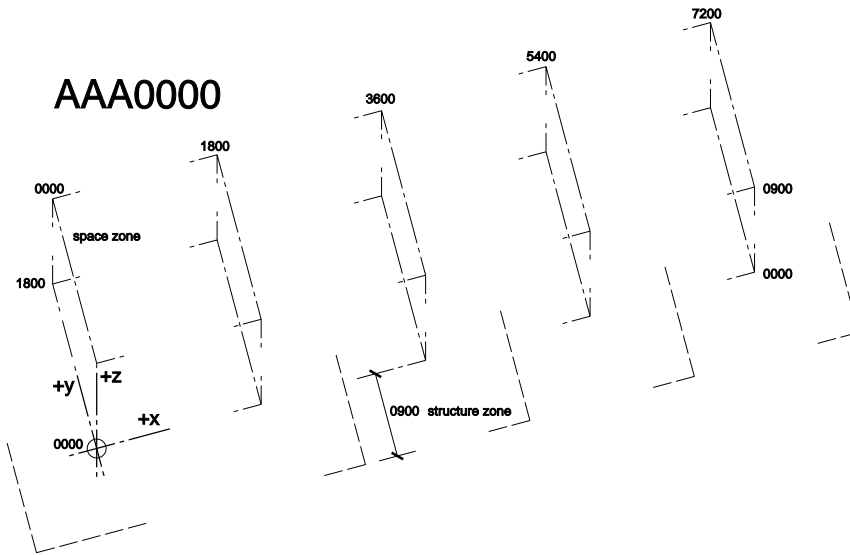

COL0200

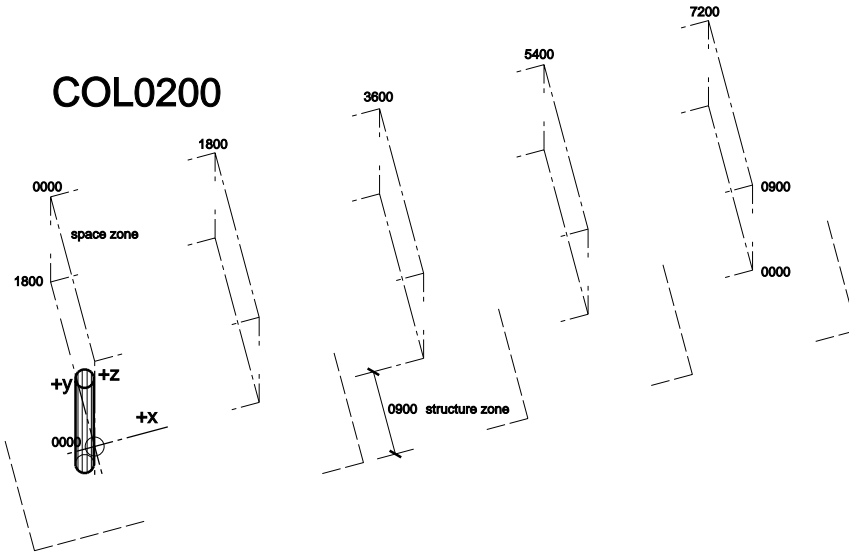

COL0350

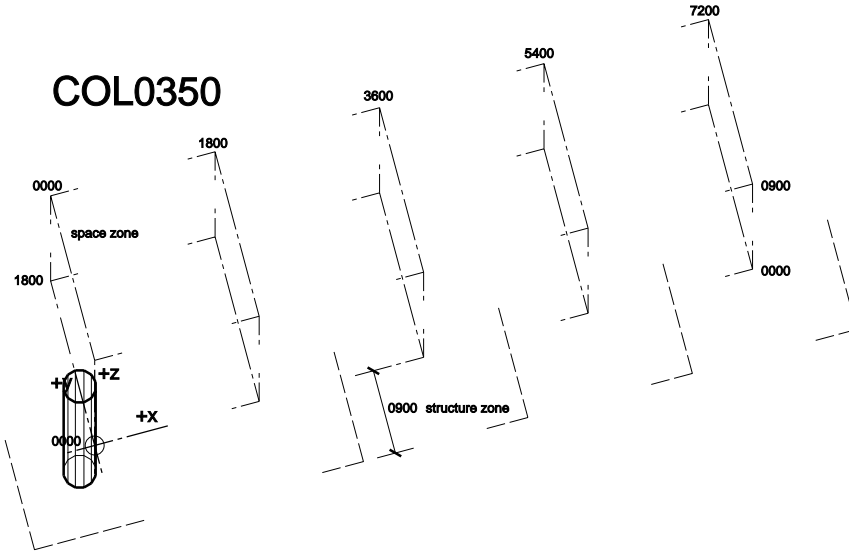

COL0800

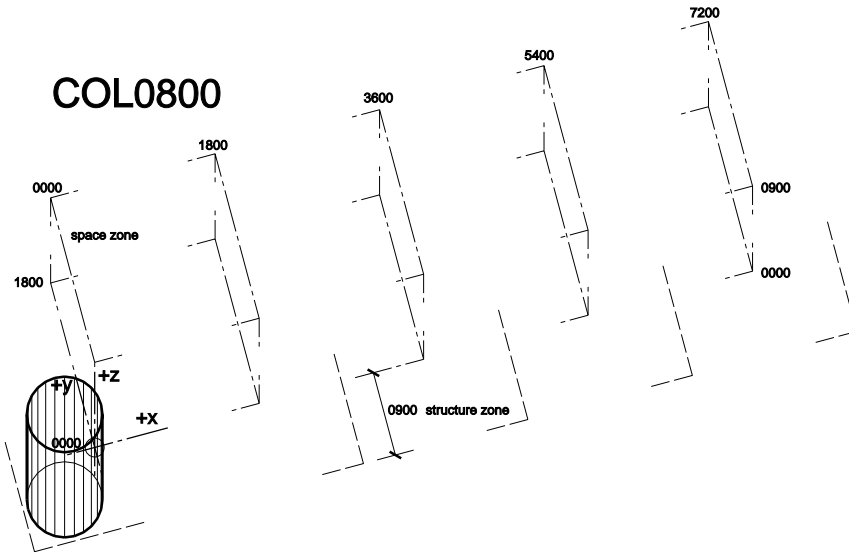

EVC0090

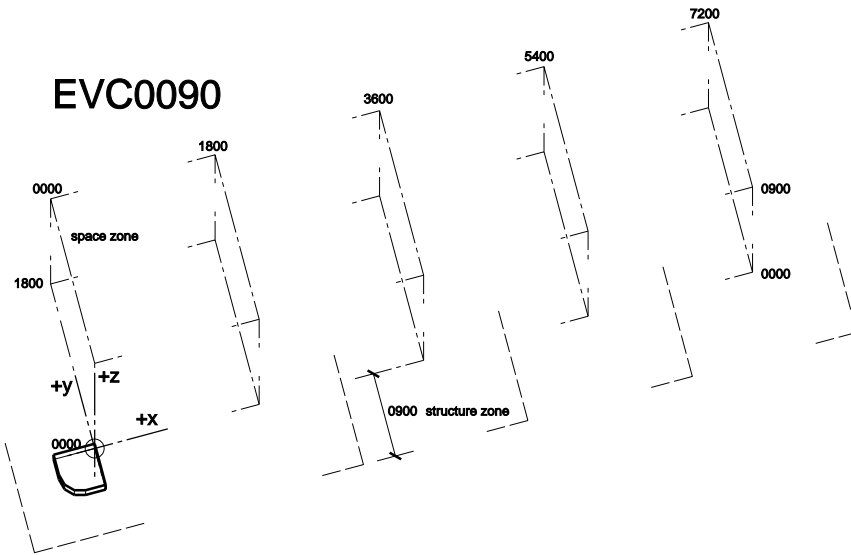

EVC0180

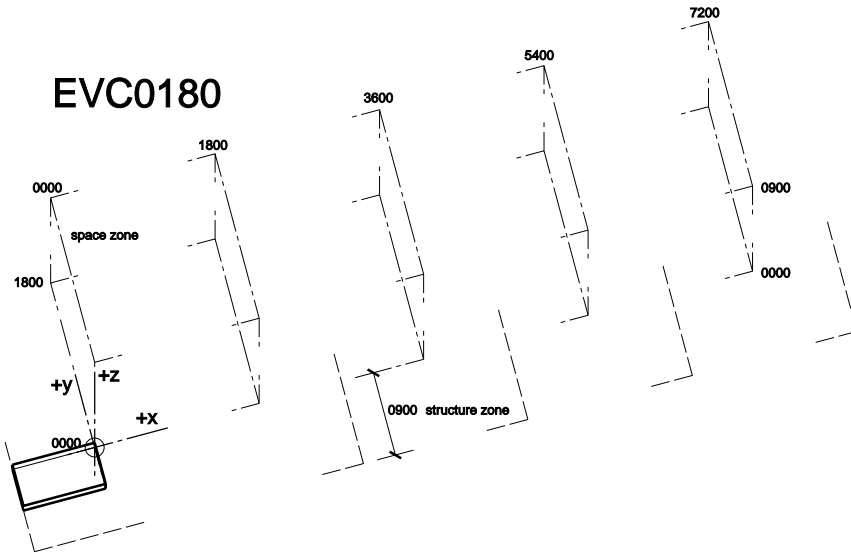

EVC0270

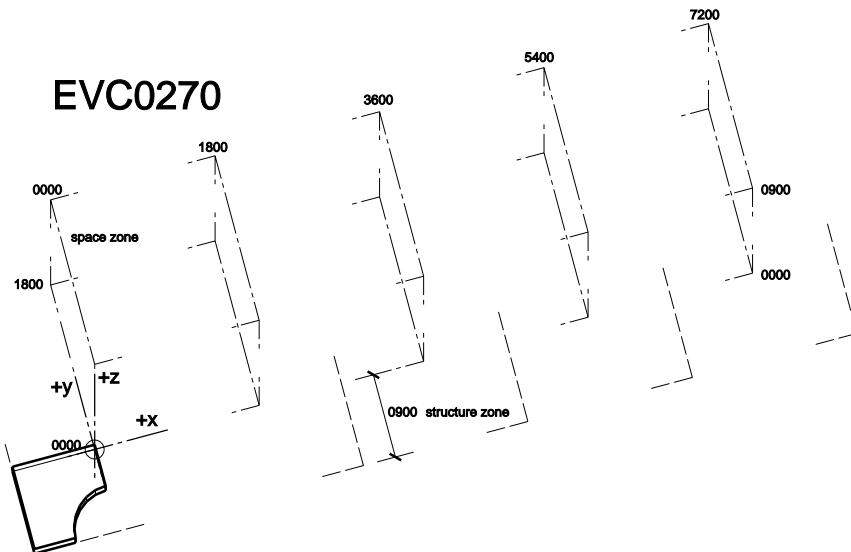

EVC1804

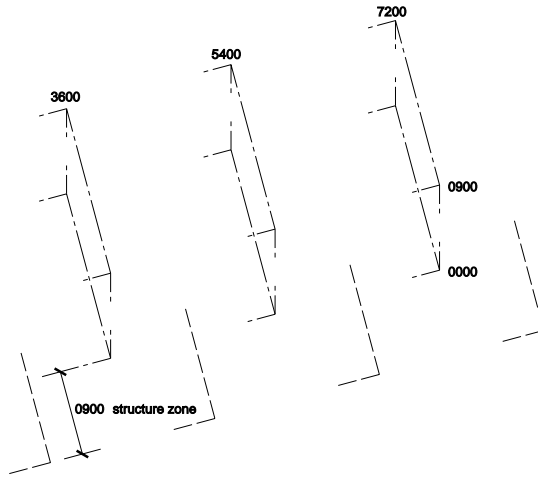
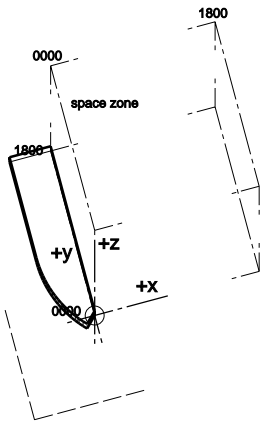

EVC1809

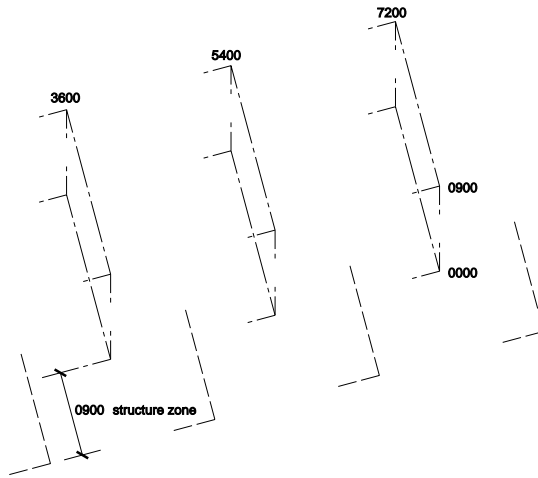
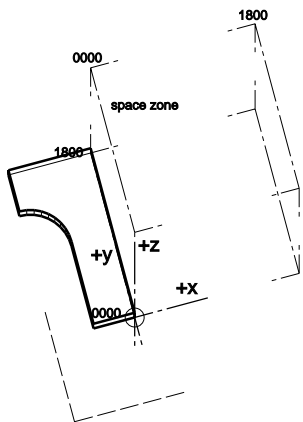

EVS0418

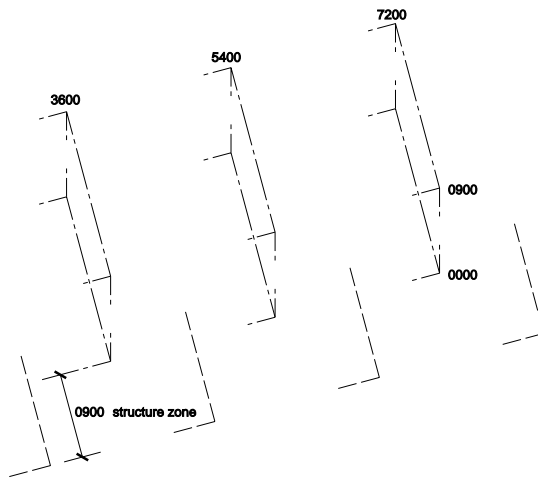
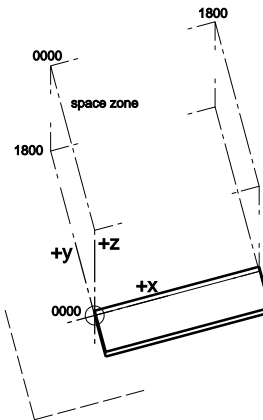

EVS0918

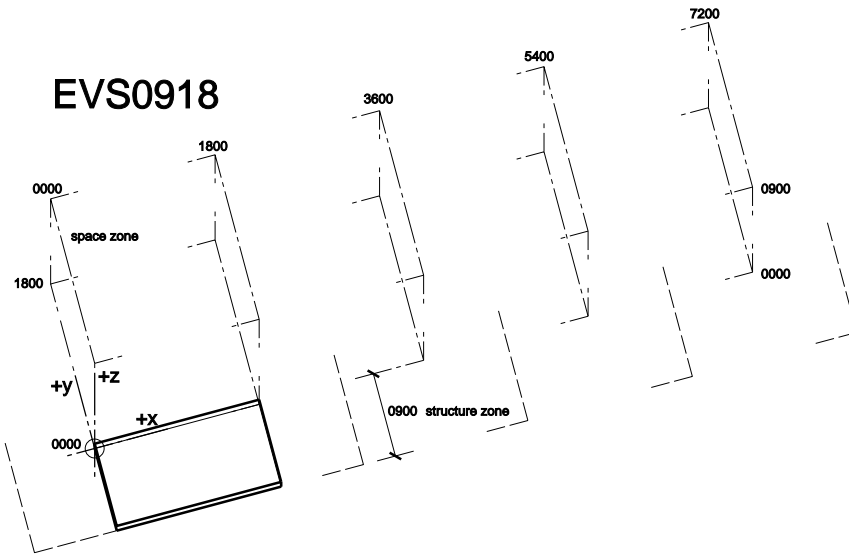

FLR0918

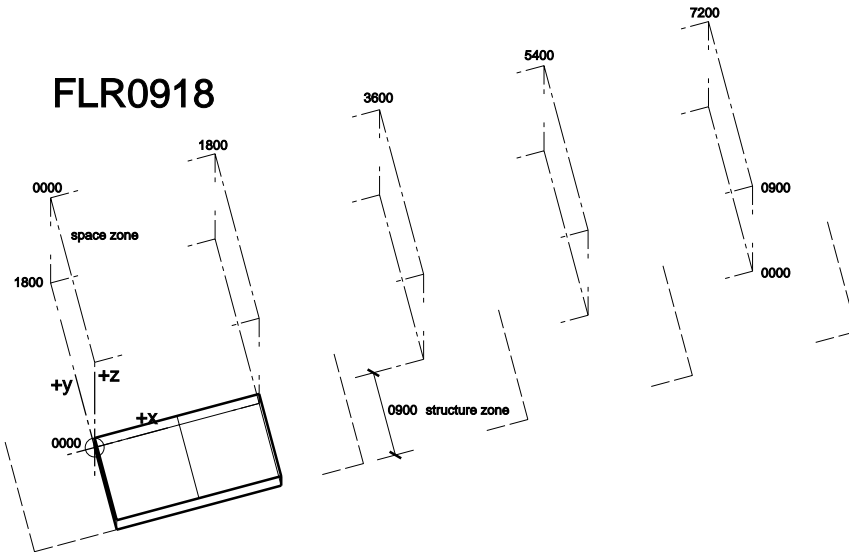

FLR1818

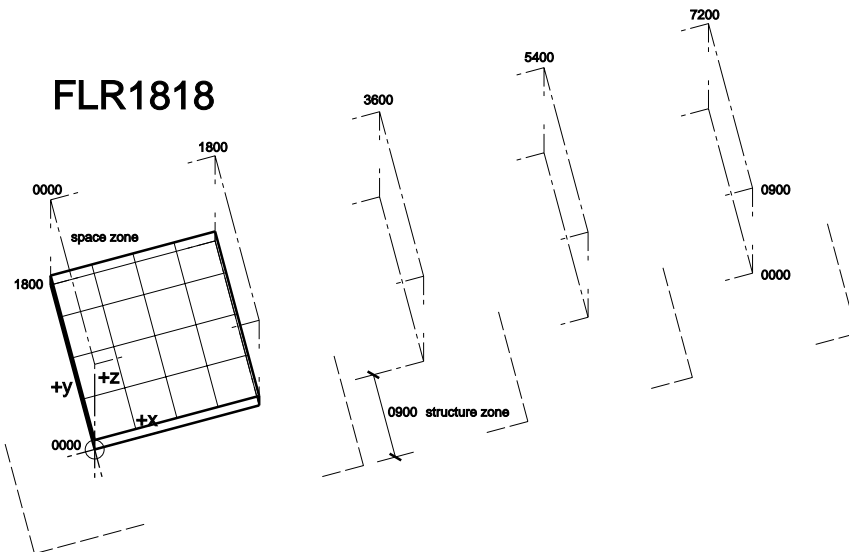

JNT0200

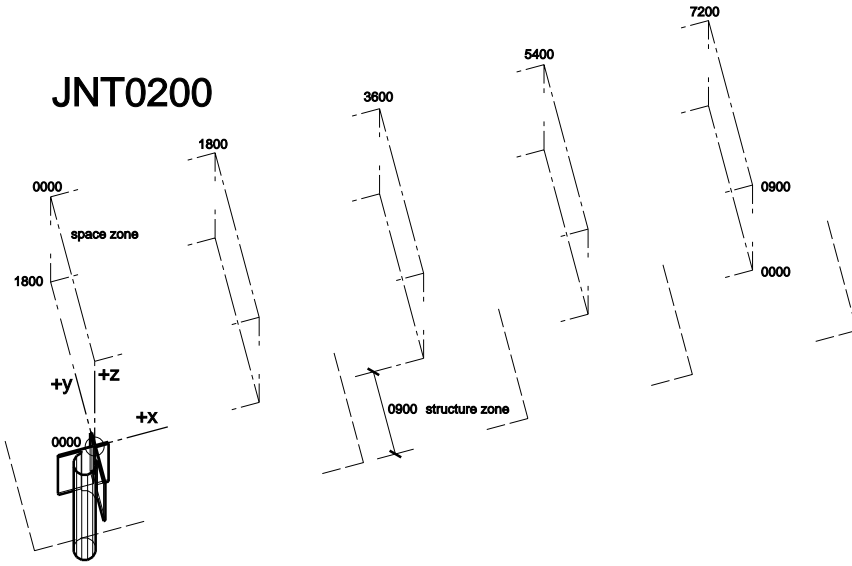

JNT0350

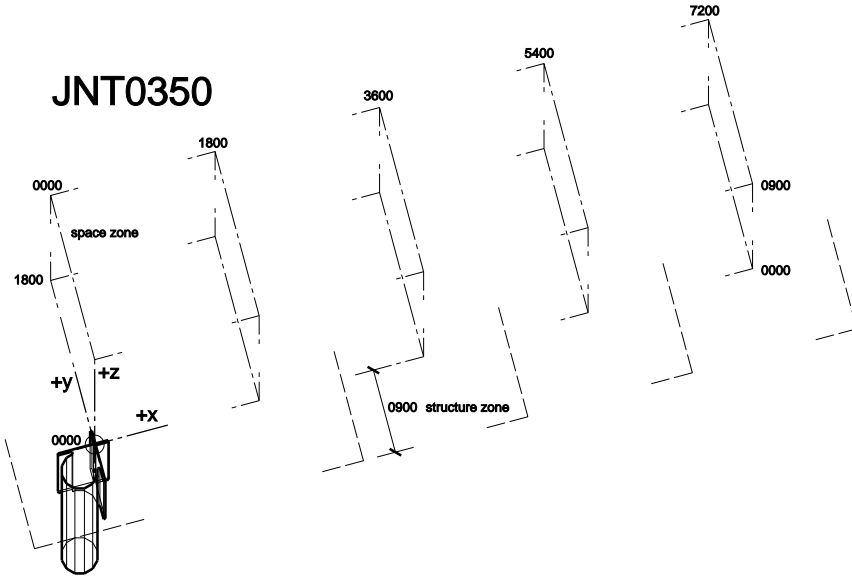

JNT0800

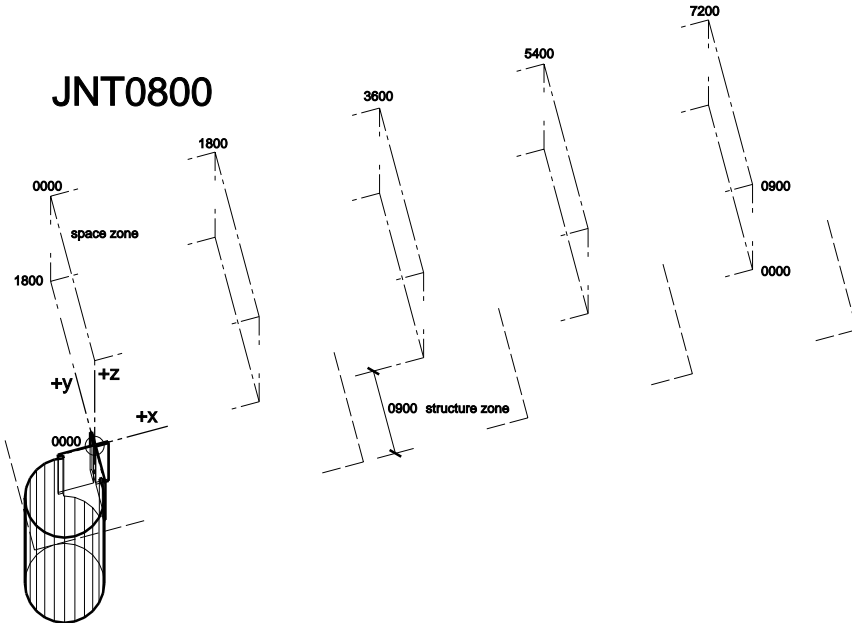

ROF1818

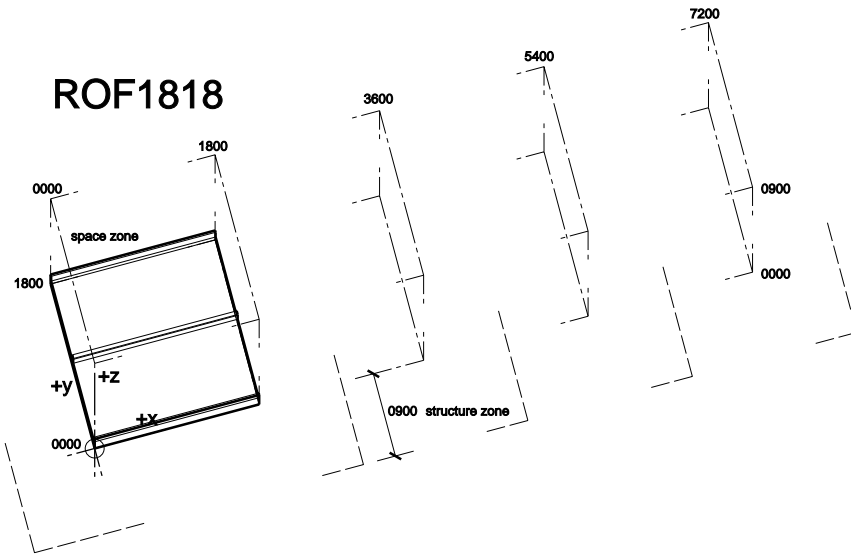

ROF1836

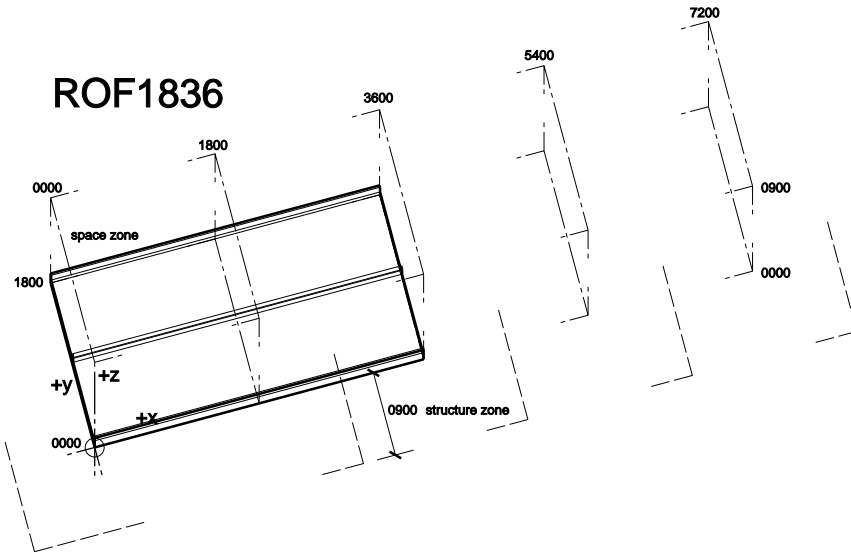

ROF1854

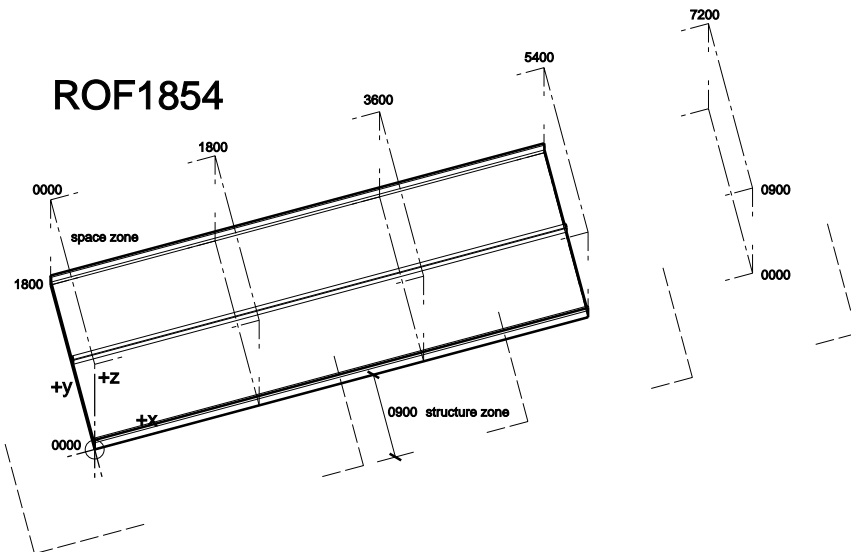

ROF1872

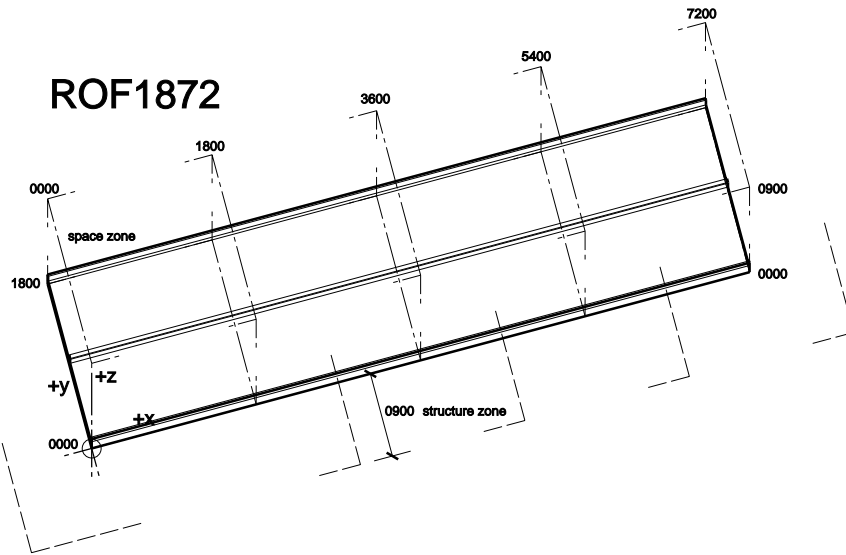

TRS0018

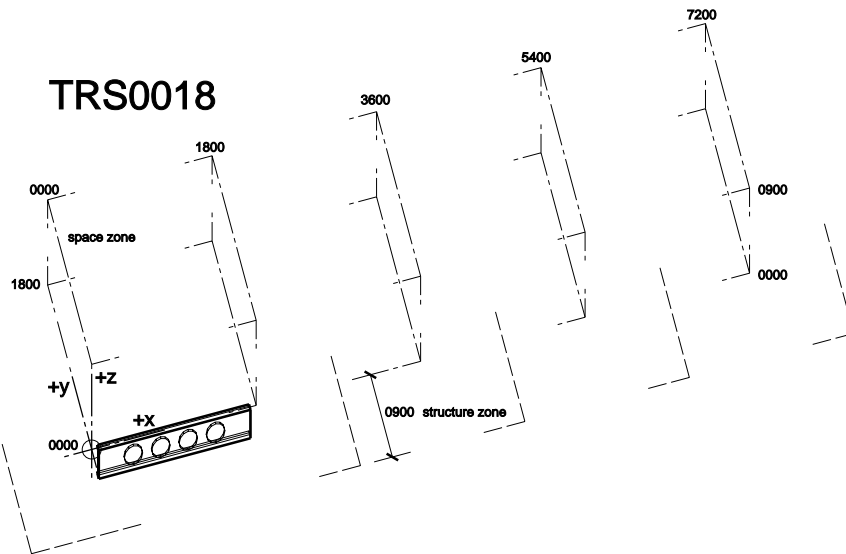

TRS0036

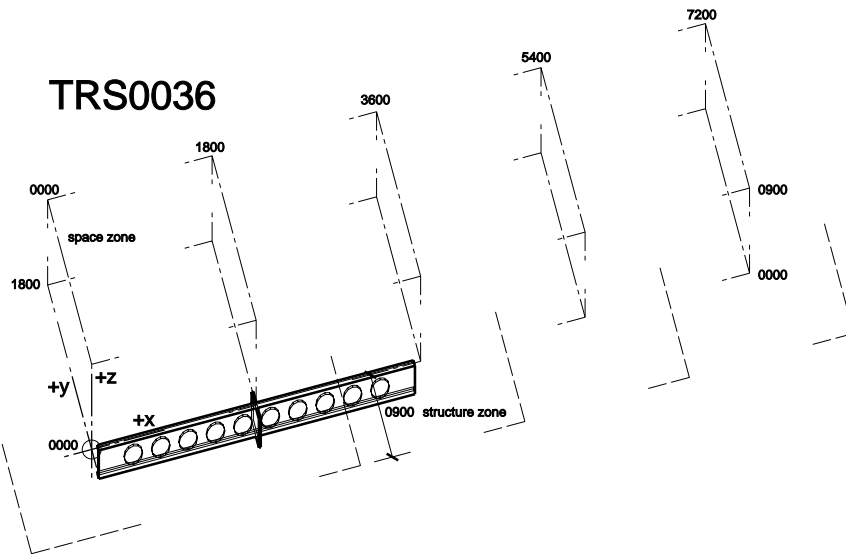

TRS0054

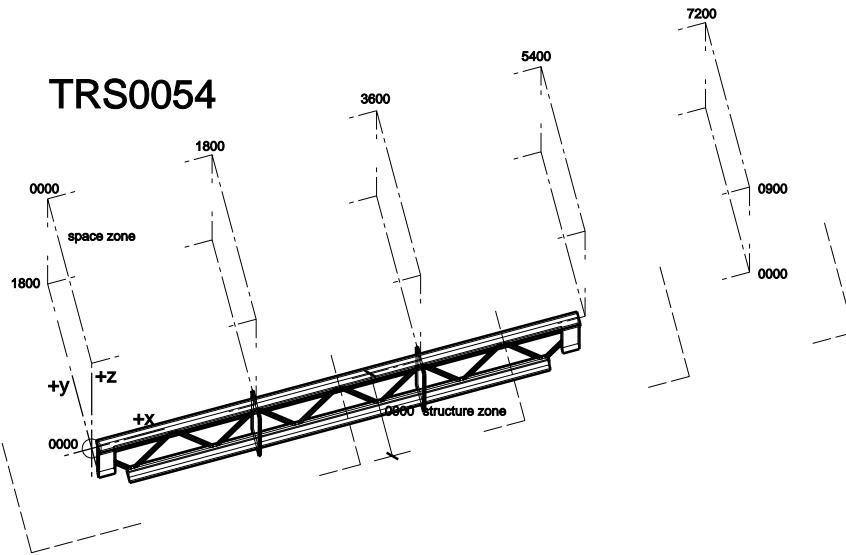

TRS0072

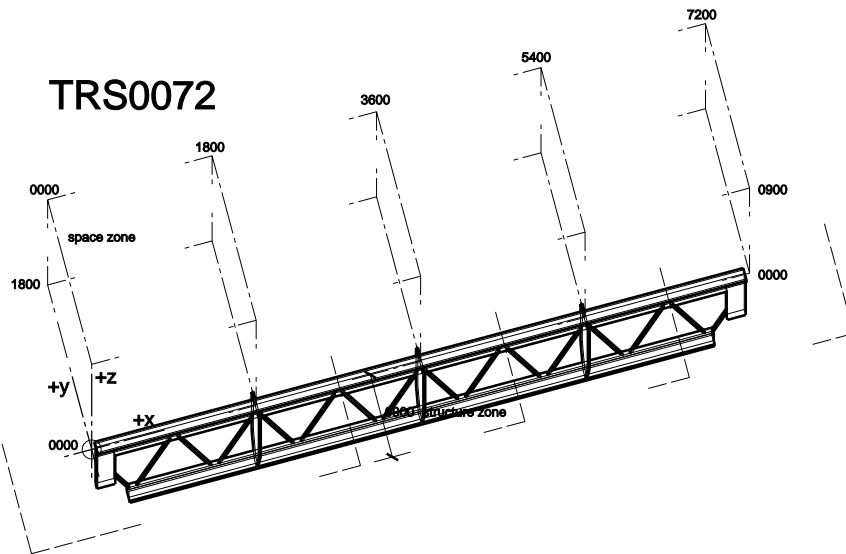

WLC0090

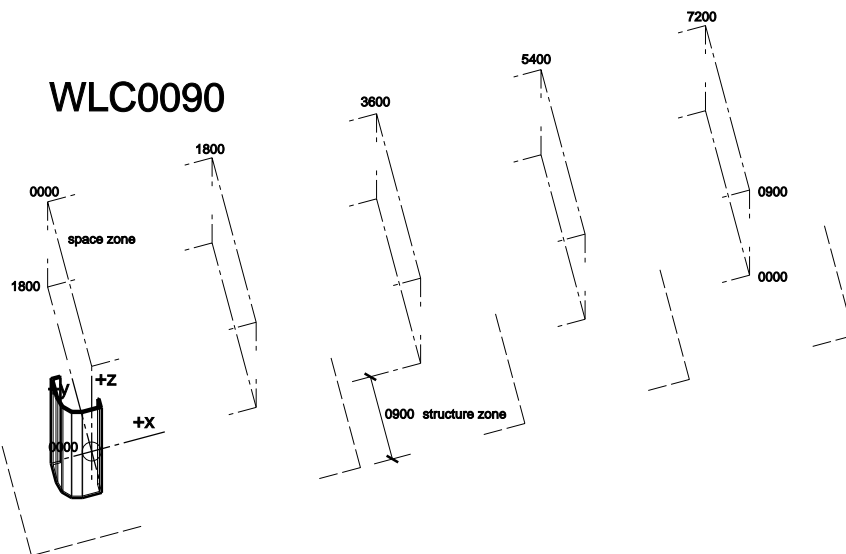

WLC0180

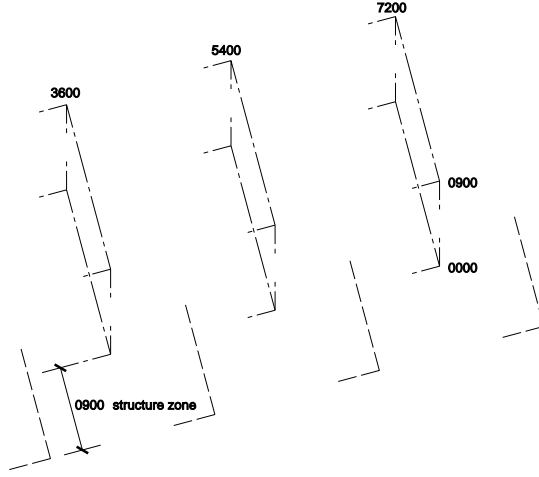
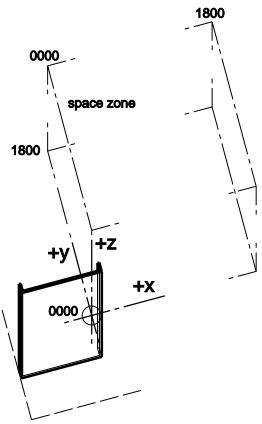

WLC0270

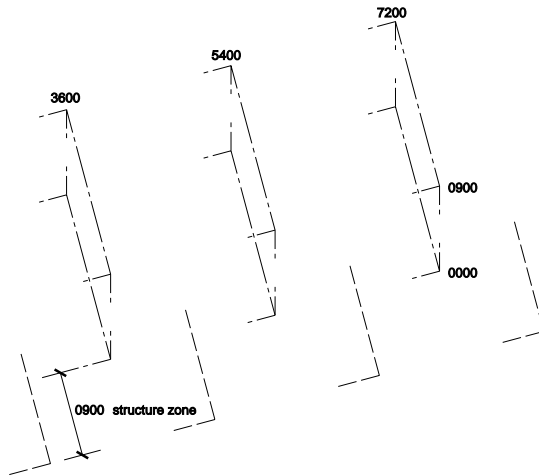
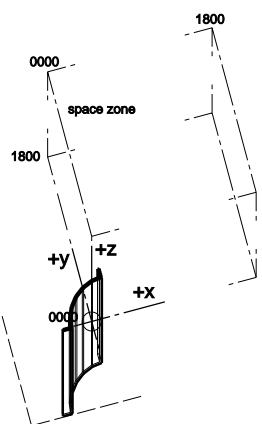

WLC0418

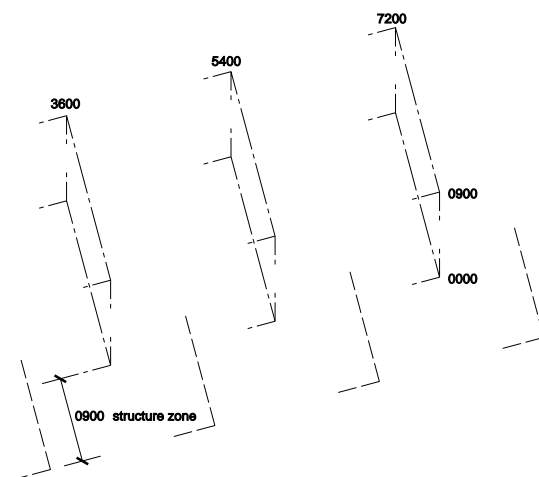
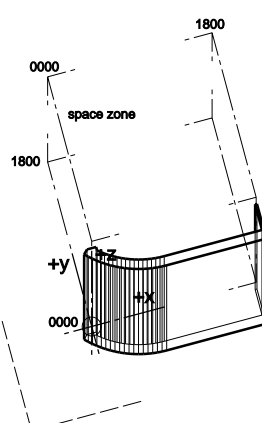

WLC0918

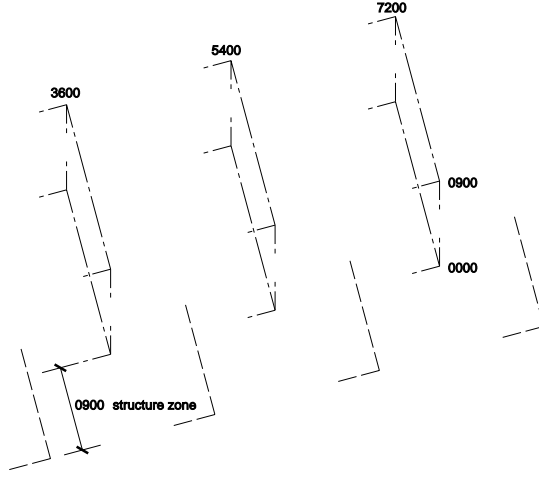
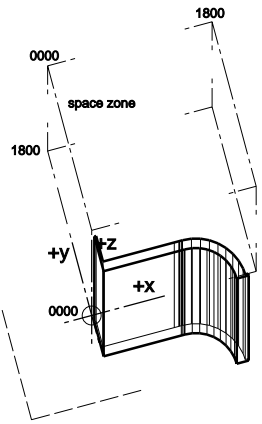

WLC1804

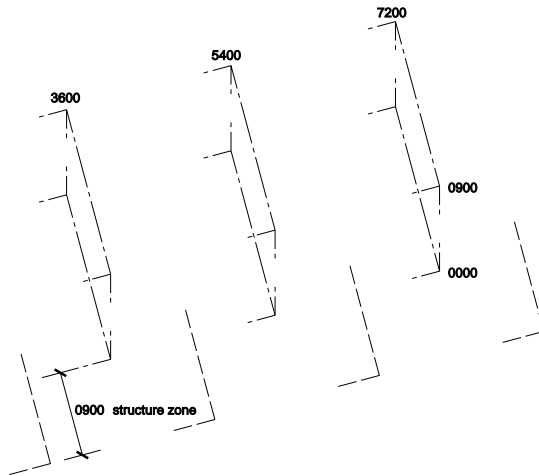
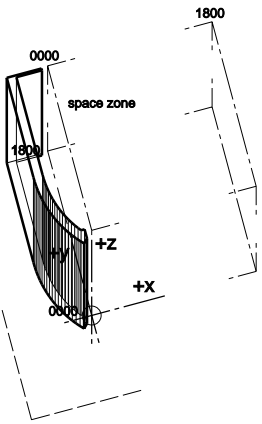

WLC1809

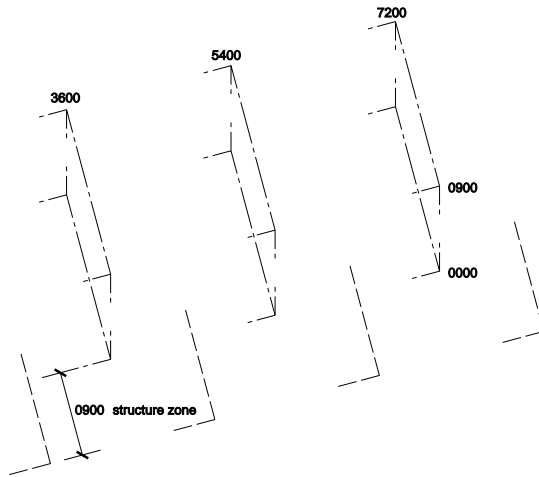
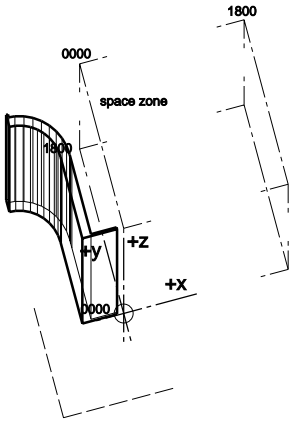

WLS0418

